

Table of Contents

Page	Title	Page	Title	Page	Title
01		31	Sensor-uC	61	+1VSB
02	CHANGE HISTORY	32	On Board-Sensors	62	+1.8VSB & Load SW
03	BLOCK DIAGRAM	33	Debug Conn	63	CHARGER
04	CLOCK DISTRIBUTION	34	Empty	64	+5V Load SW
05	SIGNAL & RESET MAP	35	SM BUS	65	+3P3V Load SW
06	POWER FLOW	36	EC-ITE 8528VG-1	66	VCPU Controller
07	POWER DISTRIBUTION	37	EC-ITE 8528VG-2/SPI ROM	67	VCORE VCCSA
08	POWER SEQUENCE	38	TPM	68	VCVGT
09	I2C MAP	39	Temp Sensor/System Fan	69	EMPTY (was GTX Reg)
10	CPU(1)_MISC,JTAG,DDI.EDP	40	REALTEK ALC298 CODEC	70	SL1 PWR/ BATT CONN.
11	CPU(2)_LPDDR3	41	Audio Jack/Vol Button/Spkr	71	SL1 SIGNALS
12	CPU(3)_SKL POWER1	42	Microphones	72	+3P3V_HPDLCD backlight/TB
13	CPU(4)_SKL_POWER2	43	M.2 SSD CONNECTOR	73	BLADE PWR
14	CPU(5)_GND	44	Empty	74	BLADE
15	CPU(6)_CFG_RESERVED	45	USB3.0	75	Power Protect
16	LPDDR3(1)_MEMORY DOWN	46	DP Dongle Control	76	Test Points
17	LPDDR3(2)_MEMORY DOWN	47	mDP		
18	XDP	48	SDXC		
19	LPDDR3(3)_CA/DQ Voltage	49	Camera IR		
20	PCH(1)_SD,HDA,RTC, CLK	50	Wi-Fi_BT		
21	PCH(2)_CLK,SMB,LPC, SPI	51	Components for ME/EMI		
22	PCH(3)_SYS PWR CONTR	52	Camera Power		
23	PCH(4)_CCI, HWID	53	Camera Rear		
24	PCH(5)_PCIE,USB	54	Camera Front		
25	PCH(6)_CPU,GPIO,MISC	55	3P3VA & BKL PWR		
26	PCH(7)_POWER	56	+VCCIO & 0P85VSB		
27	PCH(8)_empty	57	eDP connector		
28	Power Monitor	58	+VCCEDRAM & +VCCEOPIO		
29	Empty	59	+5VSB & +3P3VSB		
30	Touch Con & Key	60	+1P2V_DUAL&+VTT		

CAD Note:

Default component footprint is SMD 0201, X5R, 1% resistors.

Property: BUILD-OPT
DNP = Do Not Place

S or DB = Replace after Debug

Y EV2p9 Schematic

Title: Table of Contents	
Engineer: Surface	
Size: A3	Project Name: Y -- EV 2.9
Date: Friday, July 17, 2015	Rev: 2.9.0
Sheet 1 of 76	

Schematics Change History

Rev.	Date	Comments
Op9	28 Oct 2014	<ol style="list-style-type: none"> Starting with G_EV1_1021-1630.DSN Added SL schematic from page 72 ...\\T\MB\DV_RELEASED\Schematic\CASTLE2_DV_2014_1021_1100.DSN Added External USB3 schematic from ...\\T\MB\DV_RELEASED\Schematic\CASTLE2_DV_2014_1021_1100.DSN Added external DP ...\\T\MB\DV_RELEASED\Schematic\CASTLE2_DV_2014_1021_1100.DSN Added IR_CAMERA from Front Camera...put in page 49 Removed page 73 PCIE GPU Added Blade from T Removed P72 T2B Pwr Transistors
Op10	3 Nov 2014	<ol style="list-style-type: none"> Changing to NVDC Replaced GTX with GT, kept bypass caps Replaced Charger with BQ24770
Op11	3 Nov 2014	<ol style="list-style-type: none"> Replace SKL-U with SKL-Y
Op12	11 Nov 2014	<ol style="list-style-type: none"> Model DDR connection from Intel SDS
Op13	18 Nov 2014	<ol style="list-style-type: none"> Added FUB information to all components Changed Decretes.. sizing caps
Op14	20 Nov 2014	<ol style="list-style-type: none"> Added +5VA_SHA Added T Cost Down/XCN's Added SL +5V load Switch & Caps Added Blade +5V load Switch & Caps
Op15	26 Nov 2014	<ol style="list-style-type: none"> Removed Boost Re-adjusted usb ports on CPU Removed Audio DSP
Op16	03 Dec 2014	<ol style="list-style-type: none"> changed +1VSB regulator changed IR Camera/added diode added power numbers from 0.91 PDG, Oct14 changed BLADE connector cpu decoupling caps changed changed +5V/+3V inductors (place holder)
Op17	05 Dec 2014	<ol style="list-style-type: none"> swapped M_A_CAA with MA_CAB on U1601/U1602 added two SAR chips, P32 remove tp's from csi lines on (p23) change from 10 ceramic to 3 tantalum-poly on usb3 typeA (p45) remove the RSENSE from output of +VCCIO(p56)/+0p85VSB(p56)/+VCCEDRAM (p58)/+VCCOPIO (p58)/+1VSB(p61)/+1P8VSB(p62) change RSENSE input to 0402 from 0603 for +VCCIO(p56)/+0p85VSB(p56)/+VCCEDRAM (p58)/+VCCOPIO (p58)/+1VSB(p61)/+1P8VSB(p62) input regulator change inductor for +VCCIO(p56)/+0p85VSB(p56)/+VCCEDRAM (p58) to HMLE20161B-1R0MDR-01 change RSENSE input to 0402 from 0603 for +5V_TS,+5V_SDXC,+5V_AUDIO,+5V,+5V_FAN(p64) change RSENSE input to 0402 from 0603 for +3P3V_PANEL,+3P3V,+3P3V_SENSOR,+1P8V_DMIC (p65) Replacing the SL connector with X908351-001 Replace PL5901 and PL5902 with CMLE042T-2R2MS-01 Replace 0402 1uF 6.3V with 0201 1uF 6.3V X5R Replace L7201 with TOKO #A919CY-100M Added VSYS -> BLADE FANG supply (p73)
Op18	09 Dec 2014	<ol style="list-style-type: none"> Reduced sizes of parts for Cameras (Resistors/Caps/Regulators)
Op19	12 Dec 2014	<ol style="list-style-type: none"> All 47uF caps become 0805/1mmZ All 10uF caps become 0402...4V/6.3V
Op20	15 Dec 2014	<ol style="list-style-type: none"> changed SAM flash to reduce size to 2x3 from 5x4 Shui Changes more Shui Changes
Op21	16 Dec 2014	<ol style="list-style-type: none"> changed SAM flash to reduce size to 2x3 from 5x5 changes from EV_schematic_issue_check_1216_JDM1.xlsx changed name of +6_12 to +V_ALWAYS_ON Removed 2 Mikes & Front Mike & added FPC conn Added 2nd BLADE connector
Op22	17 Dec 2014	<ol style="list-style-type: none"> Replaced SD connector with AY531465T changes from EV_schematic_issue_check_viola_1217_JDM1.xlsx
Op23 current		<ol style="list-style-type: none"> See apexUfixes_revXpXX.xlsx

CAD Note:

Default component footprint is SMD 0201, X5R, 1% resistors

S = Short after design fixed

Property: BUILD-OPT

DNP = Not Installed Part.

Title: CHANGE HISTORY-1	
Engineer: Surface	
Size A3	Project Name Y -- EV 2.9
Date: Friday, July 17, 2015	Rev 2.9.0
Sheet 2 of 76	

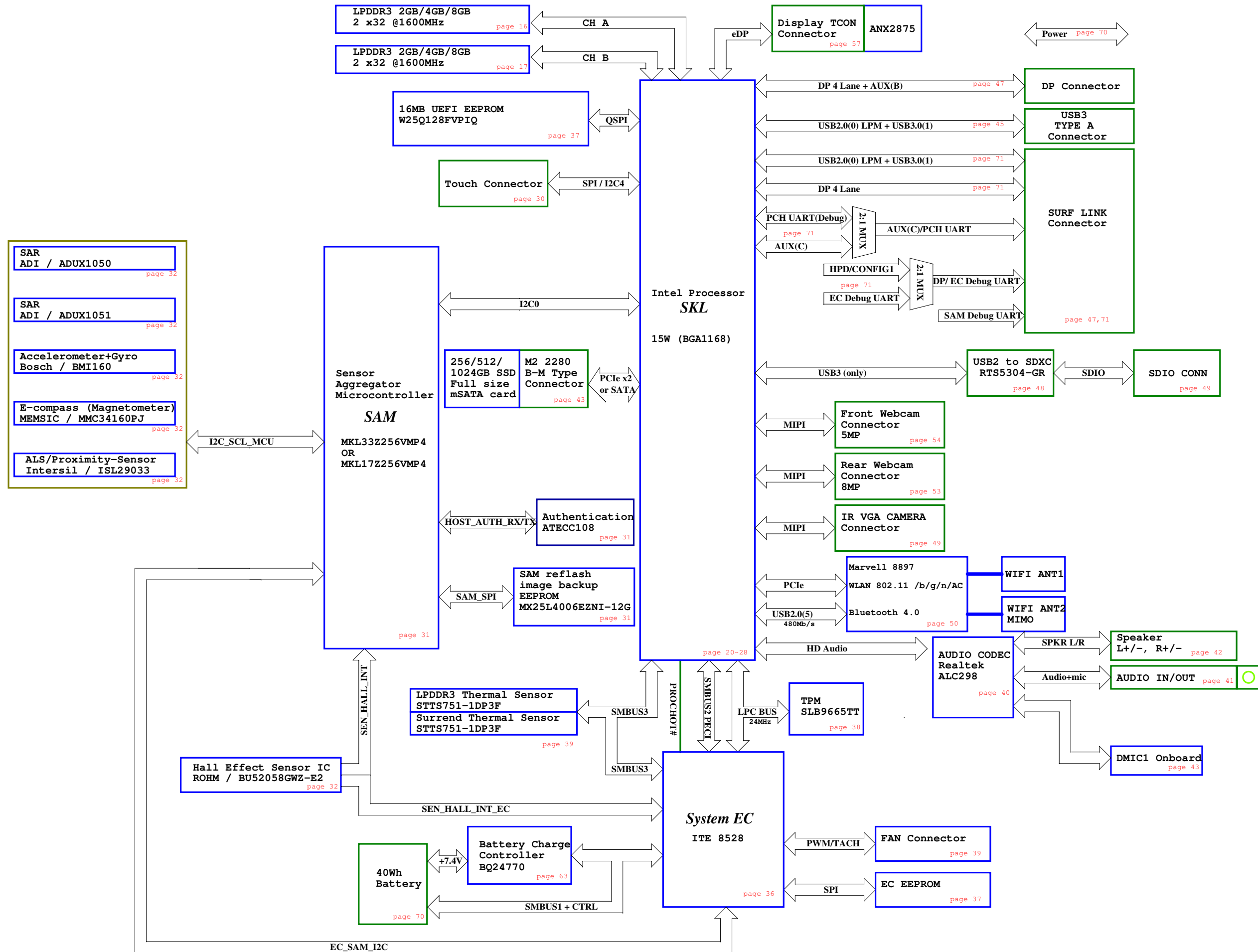

HSW Buffer Through Mode for Pre-Silicon

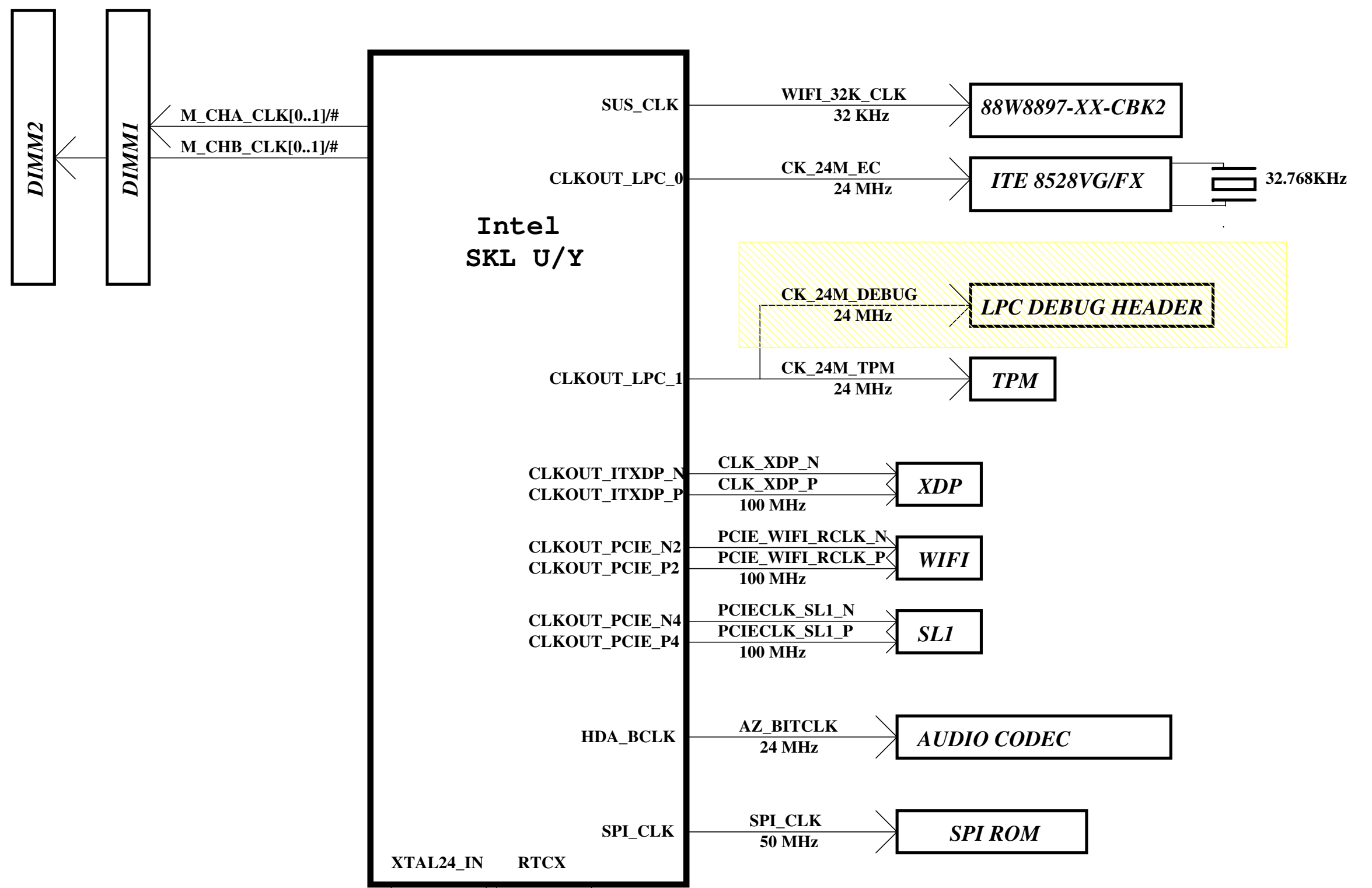

Y EV2p9 Schematic

Title: CLOCK DISTRIBUTION(TBD)		
Microsoft		Engineer: Surface
Size A3	Project Name Y -- EV 2.9	Rev 2.9.0
Date: Friday, July 17, 2015	Sheet 4 of 76	

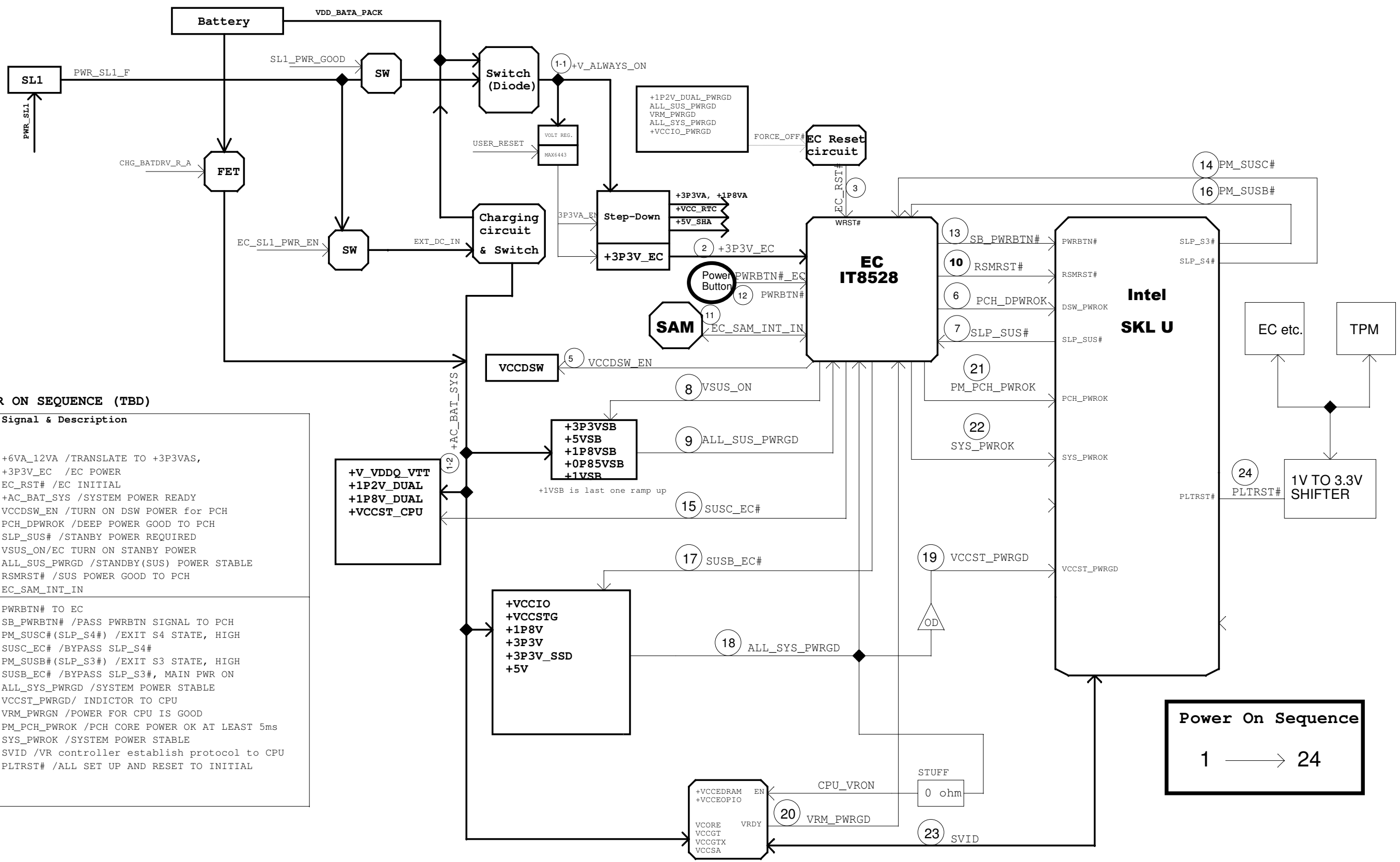

POWER ON SEQUENCE (TBD)

STEP	Signal & Description
1	+6VA_12VA /TRANSLATE TO +3P3VAS,
2	+3P3V_EC /EC POWER
3	EC_RST# /EC INITIAL
4	+AC_BAT_SYS /SYSTEM POWER READY
5	VCCDSW_EN /TURN ON DSW POWER for PCH
6	PCH_DPWRK /DEEP POWER GOOD TO PCH
7	SLP_SUS# /STANBY POWER REQUIRED
8	VSUS_ON/EC TURN ON STANBY POWER
9	ALL_SUS_PWRGD /STANDBY(SUS) POWER STABLE
10	RSMRST# /SUS POWER GOOD TO PCH
11	EC_SAM_INT_IN
12	PWRBTN# TO EC
13	SB_PWRBTN# /PASS PWRBTN SIGNAL TO PCH
14	PM_SUSC#(SLP_S4#) /EXIT S4 STATE, HIGH
15	SUSC_EC# /BYPASS SLP_S4#
16	PM_SUSB#(SLP_S3#) /EXIT S3 STATE, HIGH
17	SUSB_EC# /BYPASS SLP_S3#, MAIN PWR ON
18	ALL_SYS_PWRGD /SYSTEM POWER STABLE
19	VCCST_PWRGD/ INDICATOR TO CPU
20	VRM_PWRGN /POWER FOR CPU IS GOOD
21	PM_PCH_PWRK /PCH CORE POWER OK AT LEAST 5ms
22	SYS_PWRK /SYSTEM POWER STABLE
23	SVID /VR controller establish protocol to CPU
24	PLTRST# /ALL SET UP AND RESET TO INITIAL

Power On Sequence
1 → 24