

# LCFC Confidential

## S550 MB Schematic Document

Ice Lake\_U42 with DDR4

2019-10  
REV: 0.3

Security Classification	LC Future Center Secret Data		Title	
Issued Date	2018/08/20	Deciphered Date	2016/08/20	
<small>THIS SHEET OF ENGINEERING DRAWING IS THE PROPRIETARY PROPERTY OF LC FUTURE CENTER, AND CONTAINS CONFIDENTIAL AND TRADE SECRET INFORMATION. THIS SHEET MAY NOT BE TRANSFERRED FROM THE CUSTODY OF THE COMPETENT DIVISION OF R&amp;D DEPARTMENT EXCEPT AS AUTHORIZED BY LC FUTURE CENTER. NEITHER THIS SHEET NOR THE INFORMATION IT CONTAINS MAY BE USED BY OR DISCLOSED TO ANY THIRD PARTY WITHOUT PRIOR WRITTEN CONSENT OF LC FUTURE CENTER.</small>				
Size	Document Number	Cover Page		Rev
C				0.1
Date: Friday, November 22, 2019   Sheet 1 of 61				

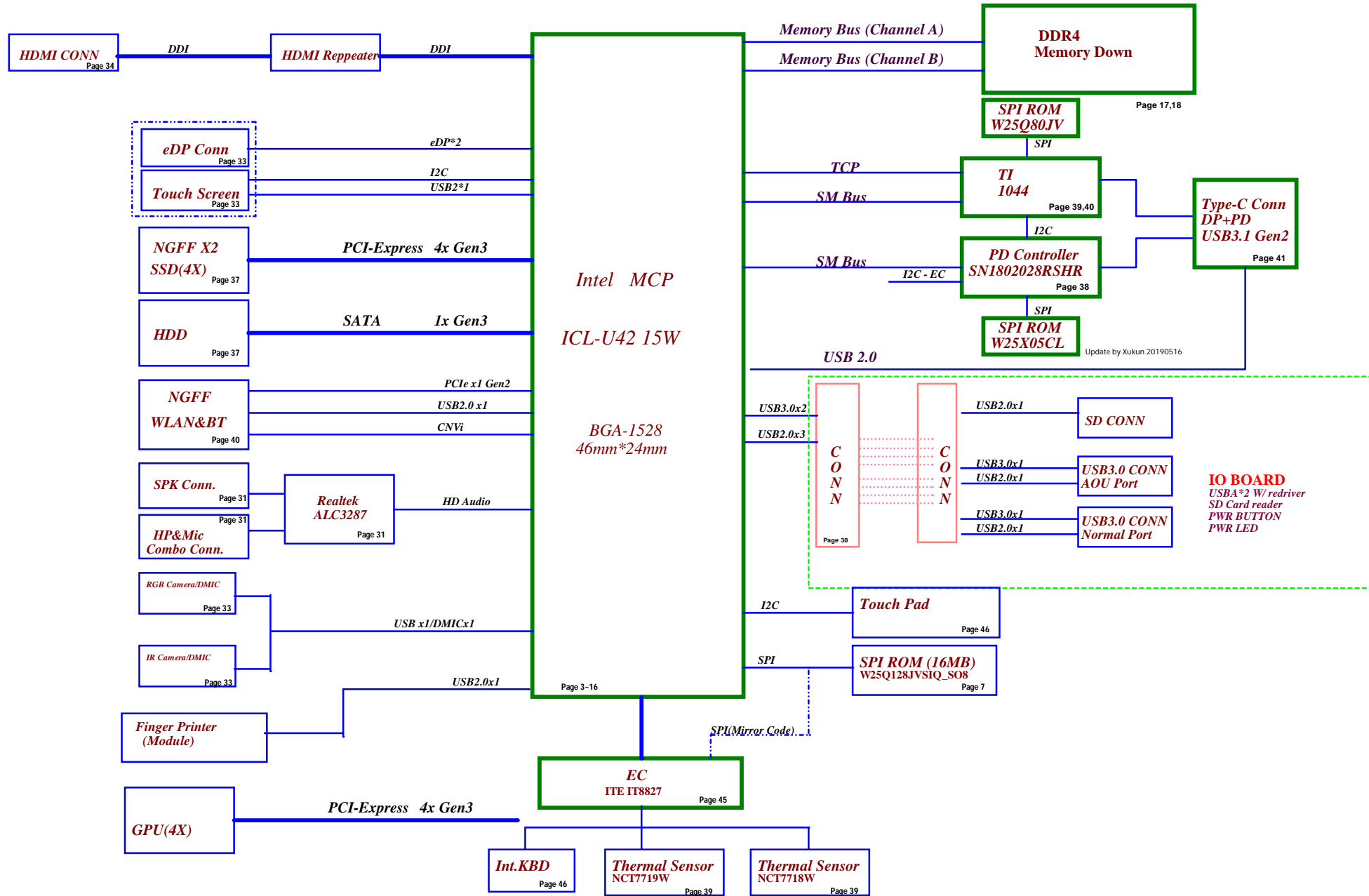



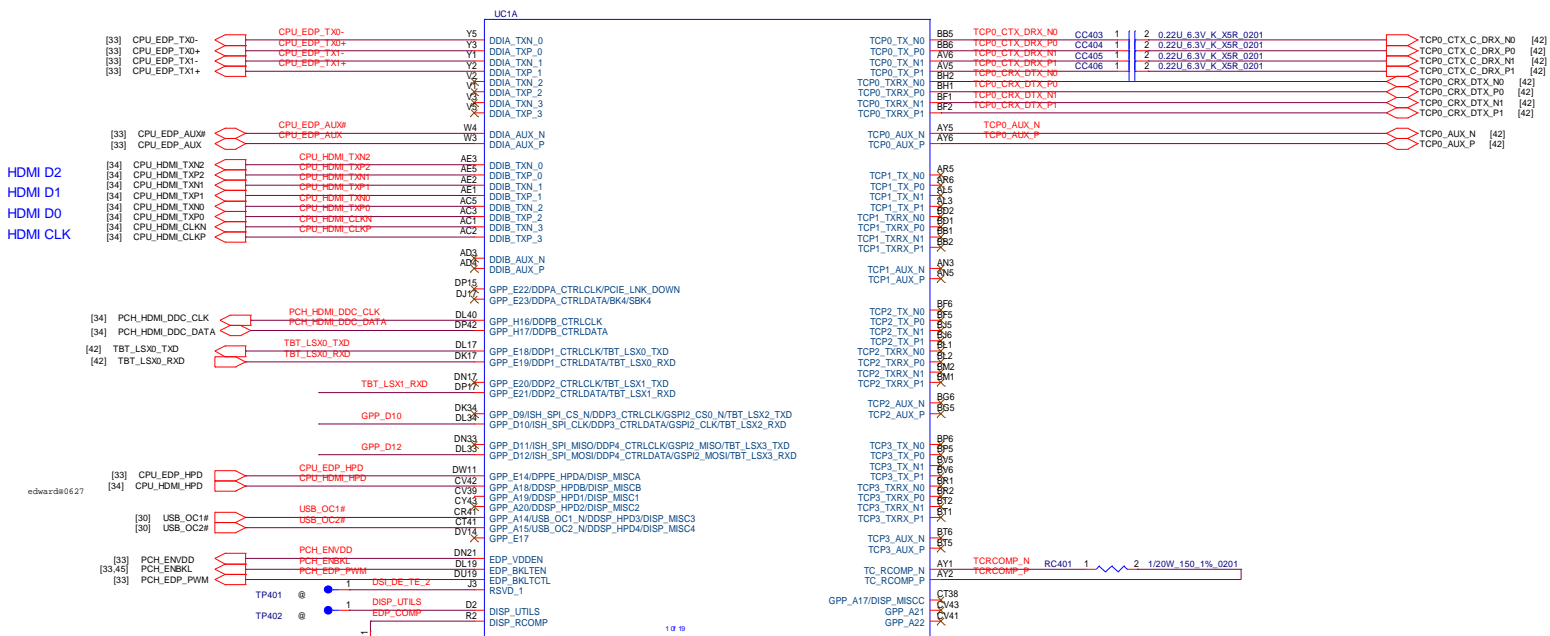

HDMI D2  
HDMI D1  
HDMI D0  
HDMI CLK

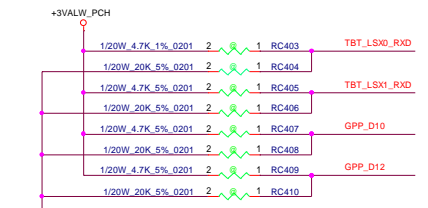
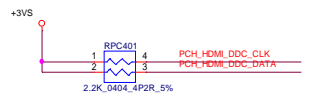

An external pull-up resistor is required if the pin is used as HDMI Display 12C, instead of TBT LxX  
0 = DDPx 12C / TBT LxX pins at 1.8V  
1 = DDPx 12C / TBT LxX pins at 1.3V

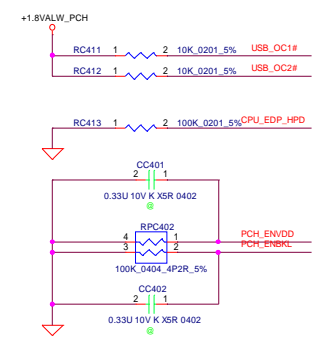

GPIO Group	Power Supply
GPP_A	1.8V
GPP_B/C/D/E	3.3V
GPP_F	1.8V(only)
GPP_G/H	3.3V
GPP_R/S	1.8V
GPD	3.3V(only)

