

Baseband Schematic

1. Contents
2. Block Diagramm
3. SOC PWR1
4. SOC PWR2
5. SOC PWR3
6. SOC HS Interface
7. SOC GPIO Interface
8. SOC RF Interface
9. SOC GND
10. PMU LDO
11. PMU BUCK & HI6422-1
12. PMU MISC & BUCKBOOST
13. HI6422-2
14. UFS and LPDDR4
15. Battery & Fuel guage
16. USB/Scharger V300/Switch
17. LCD Interface
18. Direct Charge LoadSwitch
19. Flash LED
20. Camera Interface
21. ISP Reserved
22. Codec HI6403
23. Audio/SPK/VIB
24. Headphone
25. Audio
26. X-Sensor1
27. X-Sensor2
28. SIM/uSD Card
29. FPC Interface
30. Test Point/Shielding

MODEM Schematic

31. RF Interface
32. APT Power
33. RF Transceiver_0
34. RF FRONT END HB
35. RF FRONT END B42
36. RF FRONT END MB
37. RF Front End LB
38. RF Front End Switch /Main ANT
39. RF Front End Diversity
40. RF Front End Diversity
41. Reserved for CDMA Modem
42. Reserved for CDMA Modem
43. Reserved for CDMA Modem
44. Reserved for CDMA Modem
45. Reserved for CDMA Modem
46. Reserved for CDMA Modem
47. Reserved for CDMA Modem
48. Reserved for CDMA Modem
49. RESERVED
50. RESERVED
51. WIFI BCM43455-BB
52. Connectivity(BT/WiFi/FM)-Power
53. Reserved
54. WIFI RF Front END
55. Reserved
56. GPS 4774
57. NFC
58. RF Transceiver2
59. Reserved
60. ANT Tuner

The type and specification of the components refer to the BOM

				ECA NO	DATE
DESIGNED		HLIAMHAMM			
REVIEWED					
		VER	PART_NUMBER	SHEET 1 OF 60	
		A		HUAWEI TECH CO.,LTD.	

2. Block Diagramm

The type and specification of the components refer to the BOM

					huawei design
				ECA NO	DATE
DESIGNED	huawei	HLIAMHAMM			
REVIEWED	huawei				
		VER	PART_NUMBER	SHEET 2 OF 60	
		A	huawei design	HUAWEI TECH CO.,LTD.	

3. SOC PWR1

Reserved for later using

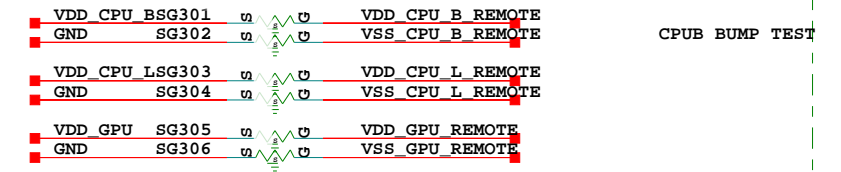

PWR1 interface 1 of 10

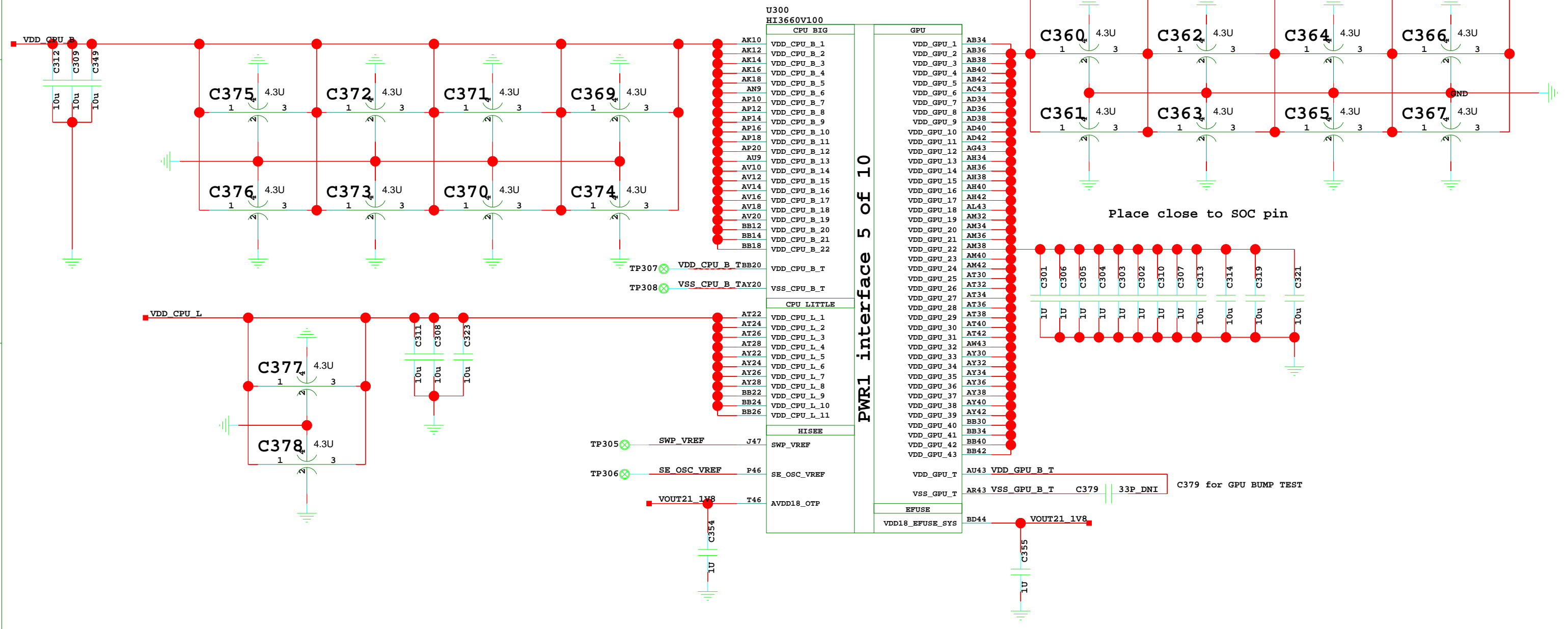

The type and specification of the components refer to the BOM

					huawei design
				ECA NO	DATE
DESIGNED	huawei	HLIAMHAMM			
REVIEWED	huawei				
		VER	PART_NUMBER	SHEET 3 OF 60	
		A	huawei design	HUAWEI TECH CO.,LTD.	

4. SOC PWR2

PWR2 interface 2 of 10

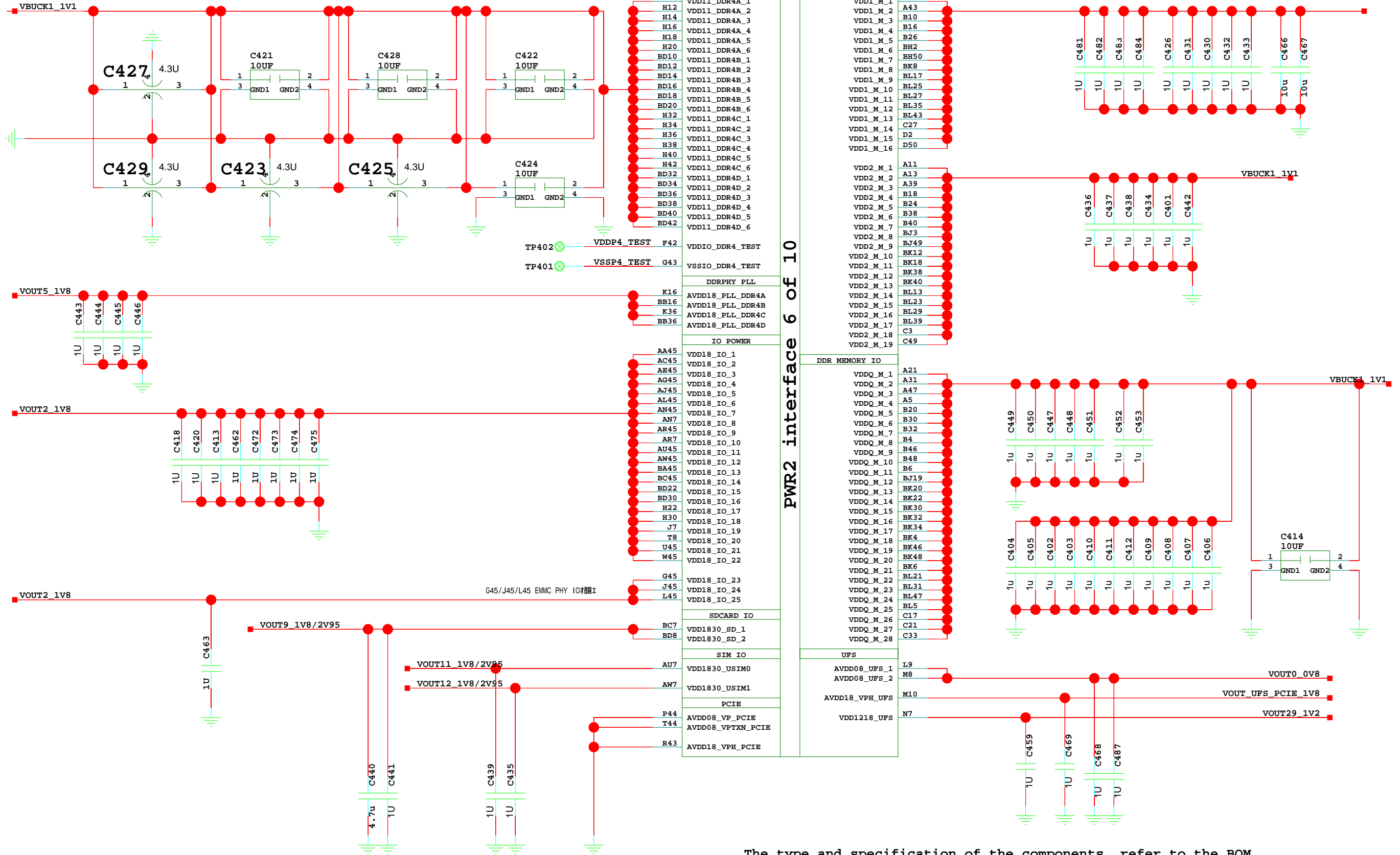

The type and specification of the components refer to the BOM

DESIGNED	huawei	HLIAMHAMM		ECA NO	huawei design
REVIEWED	huawei	HLIAMHAMM		DATE	
VER	A	PART_NUMBER	huawei design	SHEET	4 OF 60
			HUAWEI TECH CO.,LTD.		

5. SOC PWR3

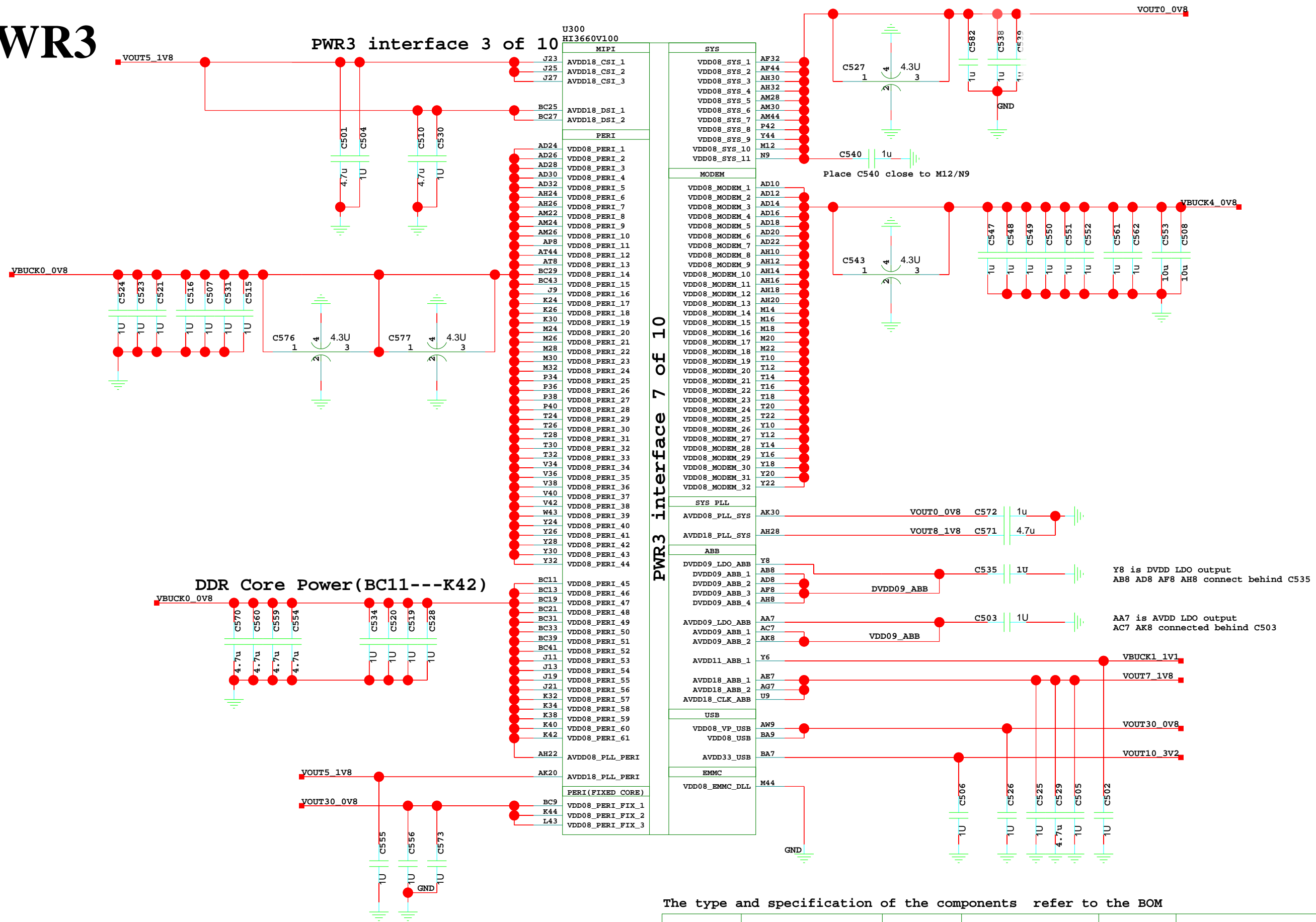

The type and specification of the components refer to the BOM

DESIGNED	huawei	HLIAMHAMM		ECA NO	huawei design
REVIEWED	huawei	HLIAMHAMM		DATE	
		VER	PART_NUMBER	SHEET 5 OF 60	
		A	huawei design	HUAWEI TECH CO.,LTD.	