

Baseband Schematic

1. Contents
2. Block Diagramm
3. SOC PWR1
4. SOC PWR2
5. SOC PWR3
6. SOC HS Interface
7. SOC GPIO Interface
8. SOC RF Interface
9. SOC GND
10. Hi6421 LDO
11. Hi6421 BUCK & Hi6423
12. Hi6421 DIGITAL INTERFACE & BUCK BOOST
13. Hi6422
14. UFS and LPDDR4X
15. Battery & Fuel gauge
16. Charge Management
17. AMOLED LCD Interface
18. Direct Charge LoadSwitch
19. Flash LED
20. Camera
21. TYPE-C EARPHONE SW
22. Codec HI6403
23. MIC/VIB
24. Headphone
25. Audio
26. X-Sensor
27. IRDA Control
28. SIM Card
29. FPC Interface
30. Test Point/Shielding

MODEM Schematic

31. RF Interface
32. RF PMU
33. RF Transceiver_HI6363 _01
34. SKY78113_ULTRA2.5_LB
35. SKY78114_ULTRA2.5_MB
36. SKY78117_ULTRA2.5_HB
37. GPA
38. RF Front End Switch
39. PRX LNA-6H01
40. DRX MHB
41. DRX_LB
42. DRX LNA Band --6H02
43. DRX2 MIMO
44. DRX3 MIMO
45. RF Transceiver_HI6363 _02
46. B42/B46 TRX
47. B42 DRX
48. Reserved
49. Reserved
50. Reserved
51. WIFI BCM43596 BB
52. WIFI BCM43596 PWR
53. Reserved
54. WIFI RF0
55. WIFI RF1
56. GPS
57. NFC
58. ANT5/6/9 GPS/WIFI ANT
59. ANT3/4 DIV ANT /ANT FPC
60. Antenna Tunner

The type and specification of the components refer to the BOM

				ECA NO	DATE
DESIGNED	zhanglihong/00392637	HL1ABLANCM		03024HUV_SCHZH	
REVIEWED	xujianguo/00312186	VER	PART_NUMBER	SHEET 1 OF 60	
		A	03024HUV	HUAWEI TECH CO.,LTD.	

2. Block Diagramm

A

A

B

B

C

C

D

D

The type and specification of the components refer to the BOM

				ECA NO	DATE
DESIGNED	zhanglihong/00392637	HL1ABLANCM		03024HUV_SCHZH	
REVIEWED	xujianguo/00312186				
		VER	PART_NUMBER	SHEET 2 OF 60	
		A	03024HUV	HUAWEI TECH CO.,LTD.	

3. SOC PWR1

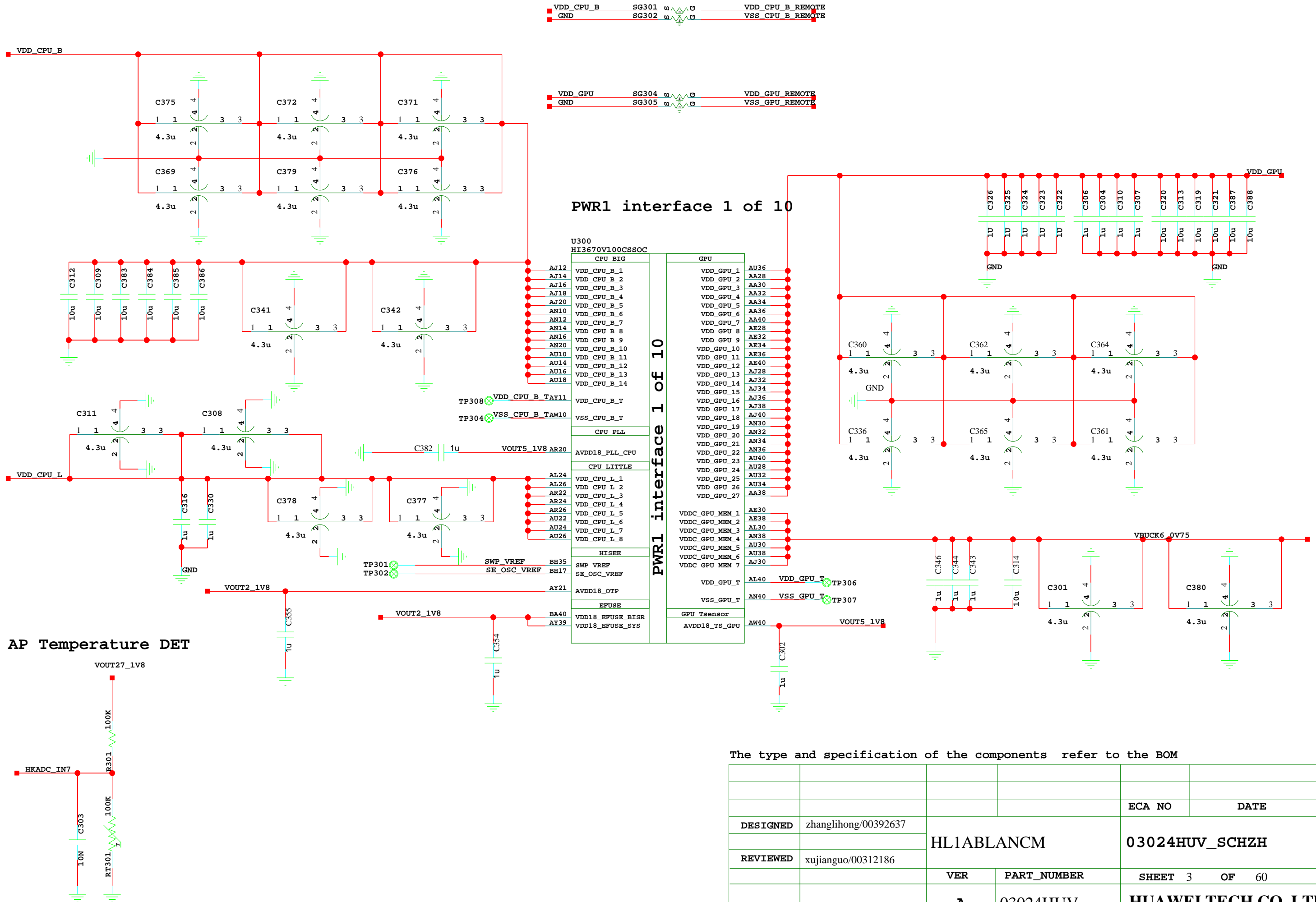

PWR1 interface 1 of 10

PWR1 interface 1 of 10

The type and specification of the components refer to the BOM

		ECA NO		DATE	
DESIGNED	zhanglihong/00392637	HL1ABLANCM		03024HUV_SCHZH	
REVIEWED	xujianguo/00312186				
VER	PART_NUMBER	SHEET 3 OF 60			
A	03024HUV	HUAWEI TECH CO.,LTD.			

4. SOC PWR2

PWR2 interface 2 of 10

Ensure VBUCK1_1V1_FB_R and VBUCK7_0V6_FB_R near the CAP

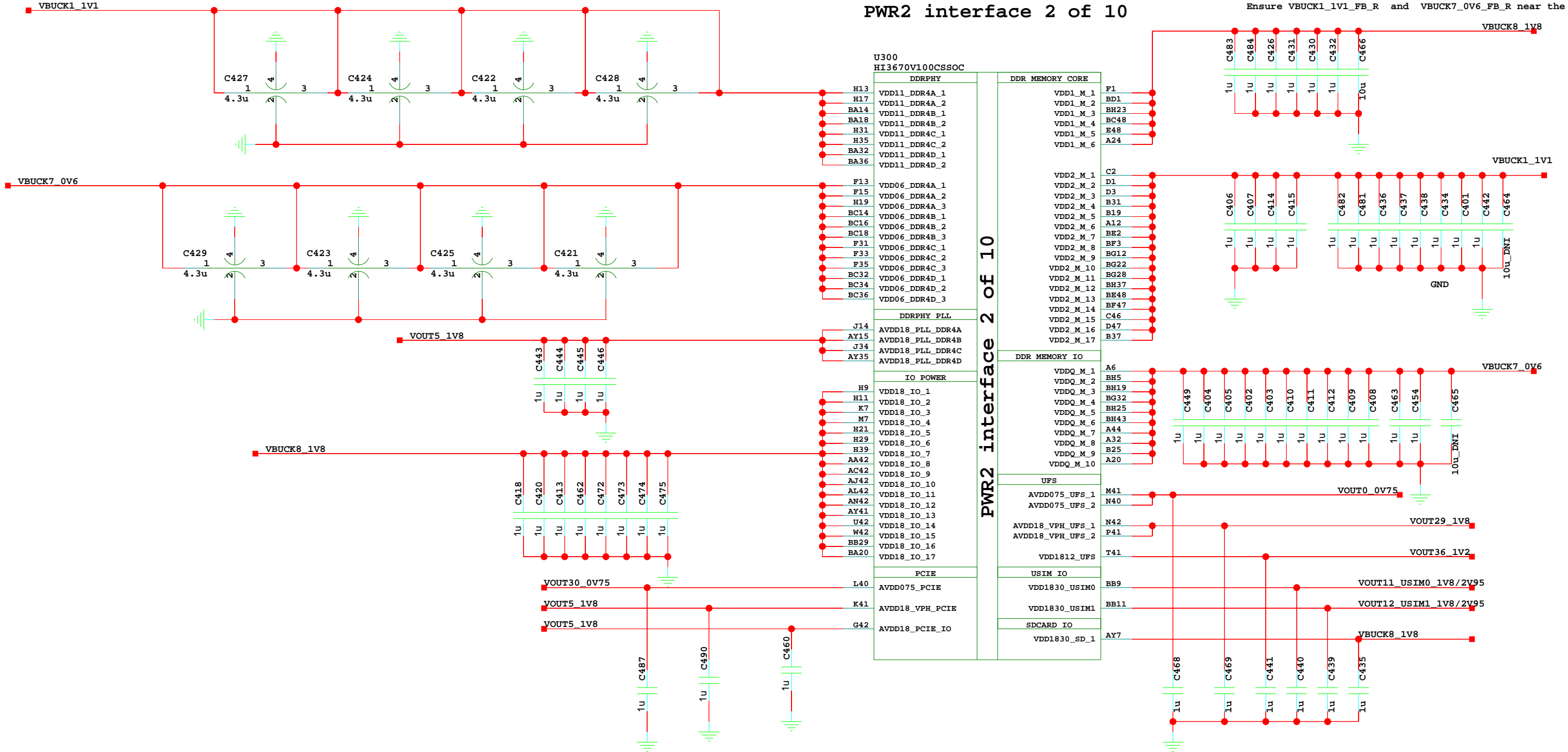

The type and specification of the components refer to the BOM

DESIGNED	zhanglihong/00392637	HL1ABLANCM		ECA NO	DATE
REVIEWED	xujianguo/00312186	03024HUV_SCHZH		SHEET 4 OF 60	
		VER	PART_NUMBER	HUAWEI TECH CO.,LTD.	
		A	03024HUV		

5. SOC PWR3

PWR3 interface 3 of 10

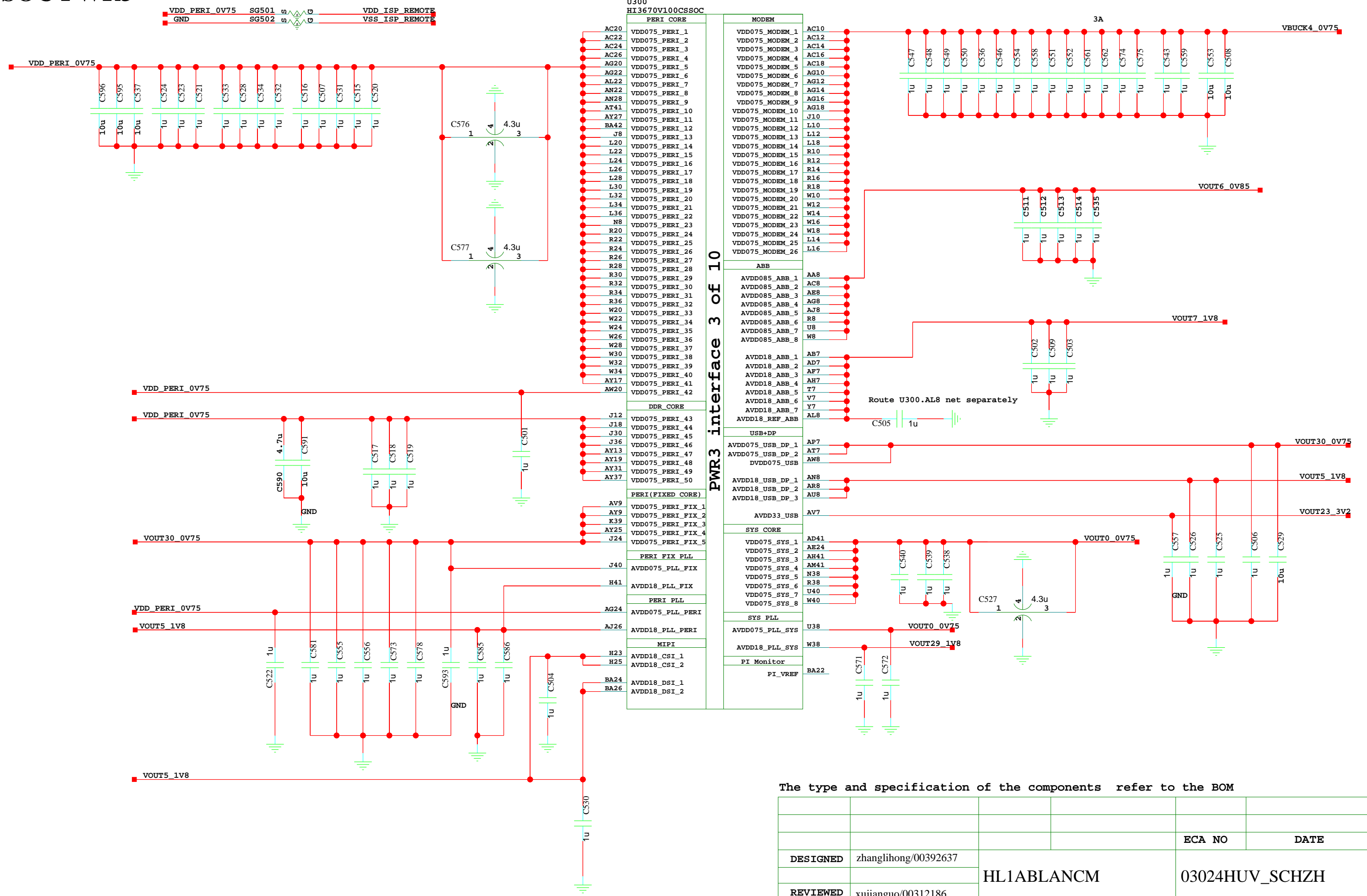

The type and specification of the components refer to the BOM

		ECA NO		DATE	
DESIGNED	zhanglihong/00392637	HL1ABLANCM		03024HUV_SCHZH	
REVIEWED	xujianguo/00312186				
VER	PART_NUMBER	SHEET 5 OF 60			
A	03024HUV	HUAWEI TECH CO.,LTD.			