

8. Level 3 Repair

8-1. Block Diagram

Prato Block Diagram

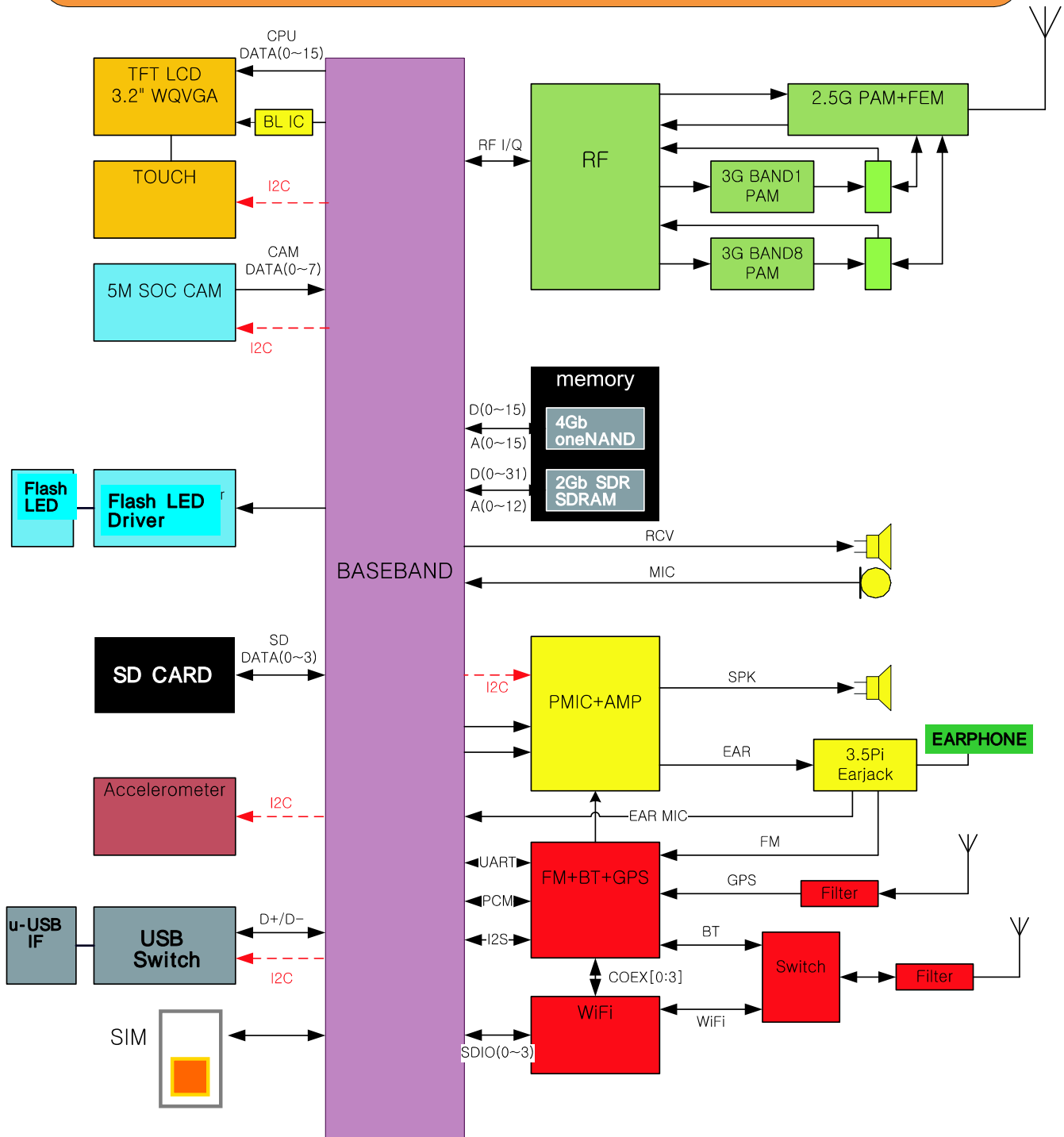

8-2. PCB Diagrams

8-2-1. Top



8-2-2. Bottom

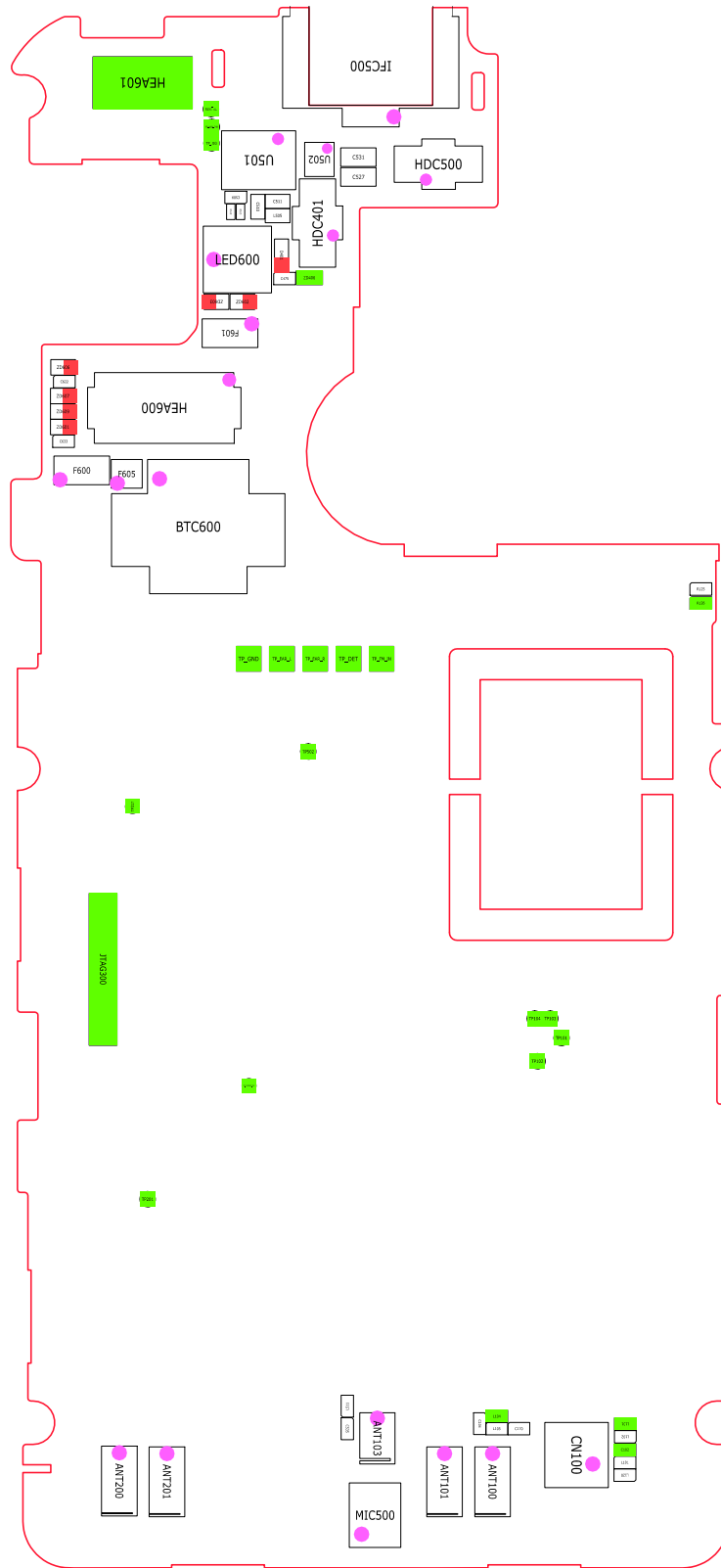

8-3-1. Power On

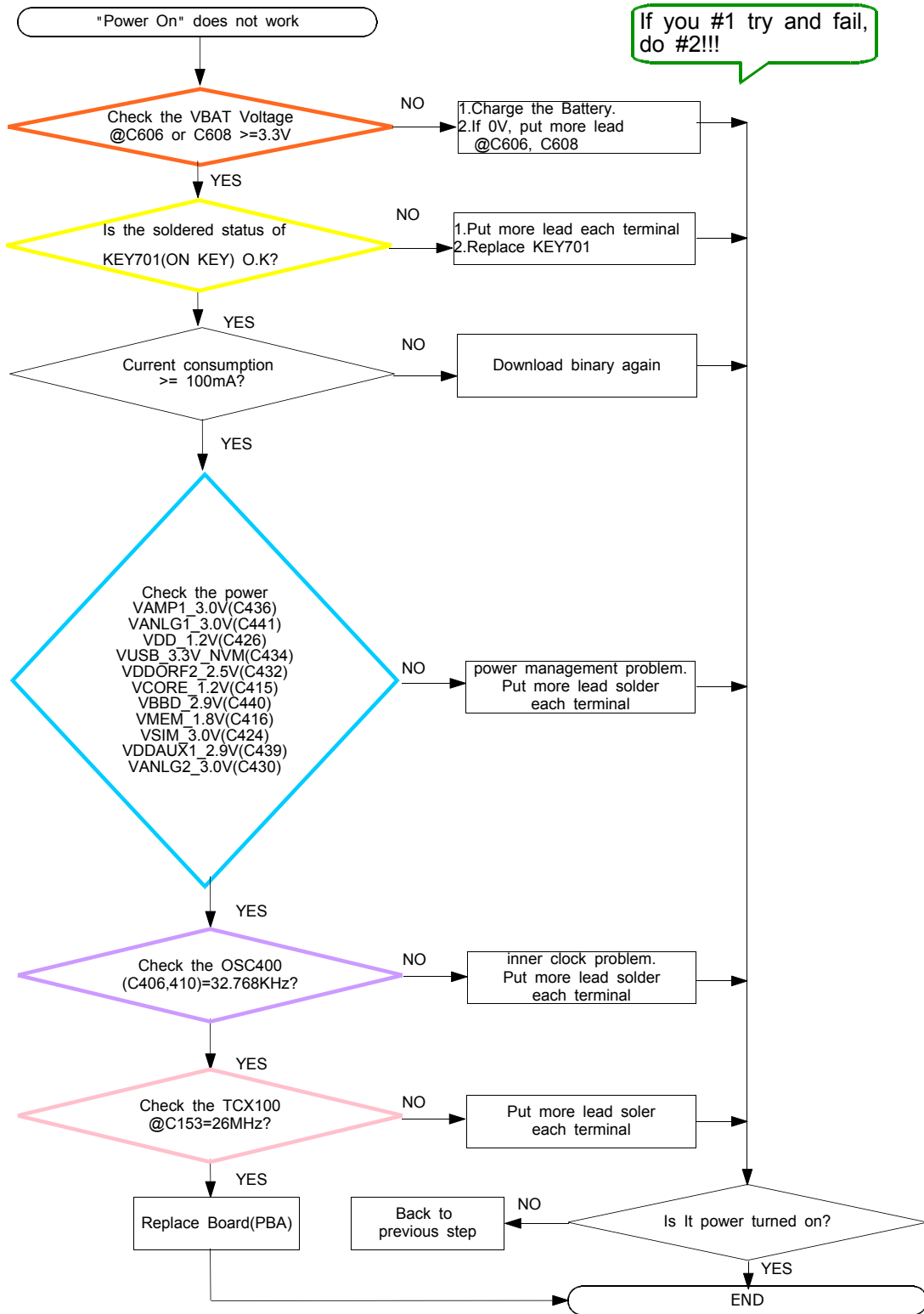

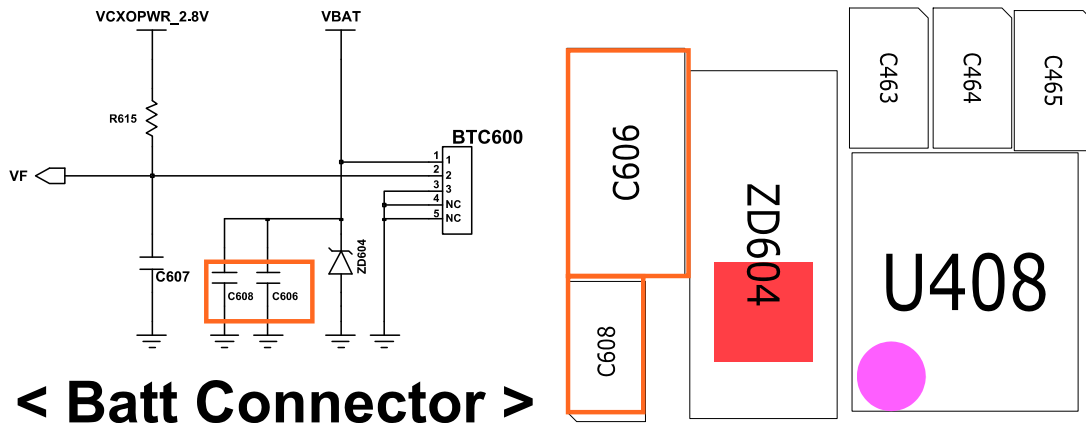

< Batt Connector >

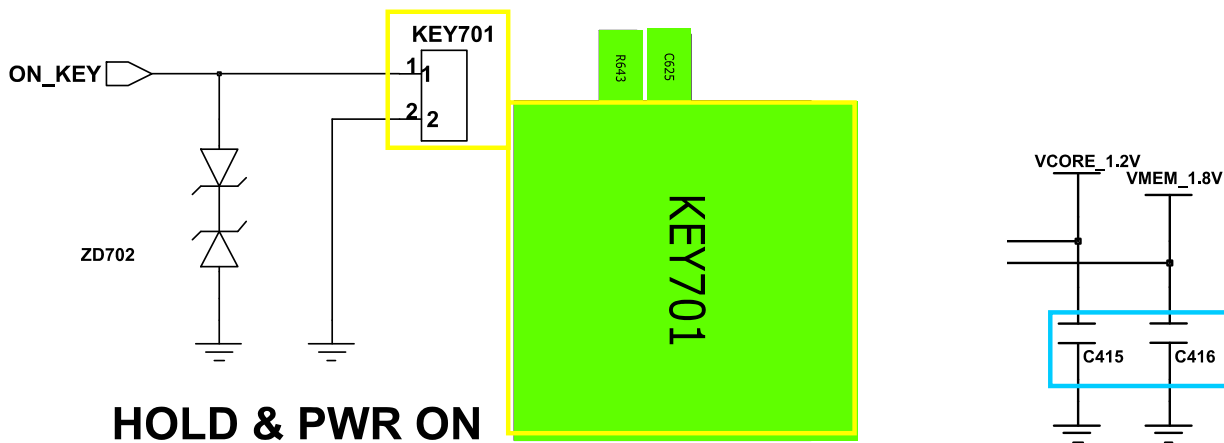

HOLD & PWR ON

