

Baseband Schematic

1. Contents
2. Block Diagramm
3. SOC PWR1
4. SOC PWR2
5. SOC PWR3
6. SOC HS Interface
7. SOC GPIO Interface
8. SOC RF Interface
9. SOC GND & NC
10. PMU LDO
11. PMU BUCK & HI6422-2
12. PMU MISC & BUCKBOOST
13. HI6422-1
14. UFS and LPDDR4
15. Battery & Fuel guage
16. Charge Management
17. AMOLED Interface
18. Direct Charge LoadSwitch
19. Flash LED
20. Camera Interface
21. ISP Reserved
22. Codec HI6403
23. MIC/VIB
24. Headphone
25. Audio
26. X-Sensor1
27. X-Sensor2
28. SIM Card
29. FPC Interface
30. Test Point/Shielding

MODEM Schematic

31. RF Interface
32. APT Power
33. RF Transceiver 0
34. RF FRONT END HB
35. RF FRONT END B42
36. RF FRONT END MB
37. RF Front End LB
38. RF Front End Switch /Main ANT
39. RF Front End Diversity
40. RF Front End Diversity
41. Reserved for CDMA Modem
42. Reserved for CDMA Modem
43. Reserved for CDMA Modem
44. Reserved for CDMA Modem
45. Reserved for CDMA Modem
46. Reserved for CDMA Modem
47. Reserved for CDMA Modem
48. Reserved for CDMA Modem
49. Reserved
50. Reserved
51. BCM43455 BB
52. BCM43455 POWER
53. Reserved
54. WLAN RF0
55. WLAN RF1
56. GPS
57. NFC
58. RF Transceiver 1
59. Reserved
60. ANT Tuner

The type and specification of the components refer to the BOM

				NA	2016-09-28
				ECA NO	DATE
DESIGNED	WangLi/00291205	HL1ALONMM		03024BRV_SCHZH	
REVIEWED	PengZhonghui/00210925	VER	PART_NUMBER	SHEET 1 OF 60	
		B	03024BRV	HUAWEI TECH CO.,LTD.	

2. Block Diagramm

The type and specification of the components refer to the BOM

				NA	2016-09-28
				ECA NO	DATE
DESIGNED	WangLi/00291205	HL1ALONMM		03024BRV_SCHZH	
REVIEWED	PengZhonghui/00210925				
		VER	PART_NUMBER	SHEET 2 OF 60	
		B	03024BRV	HUAWEI TECH CO.,LTD.	

3. SOC PWR1

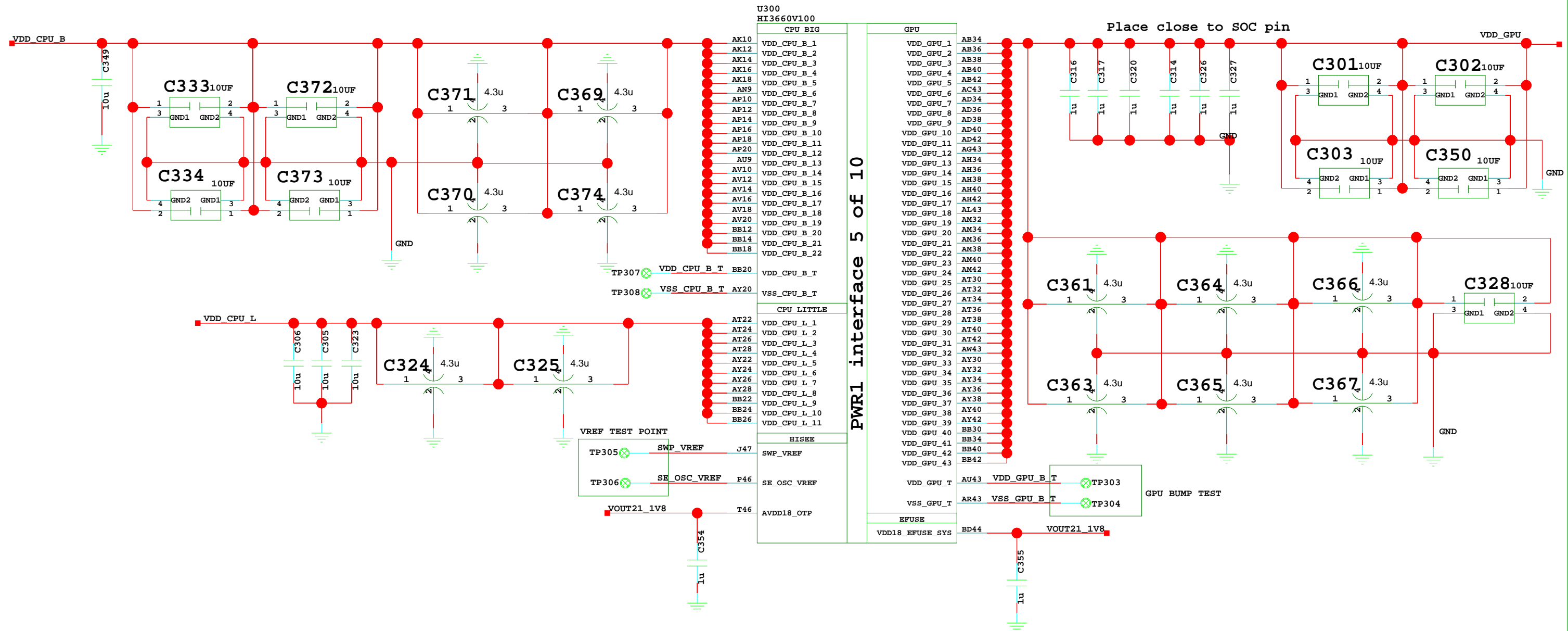
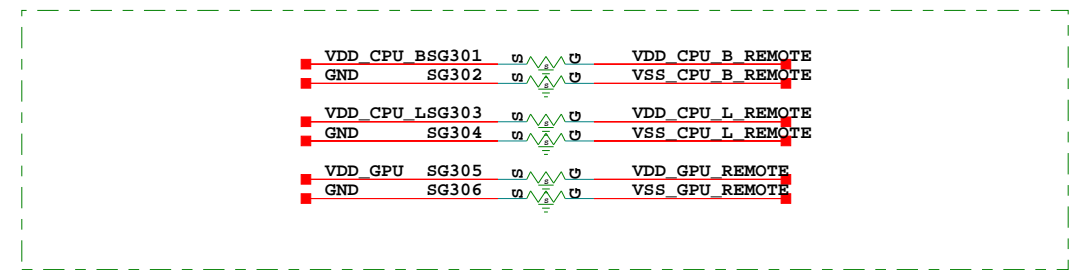

The type and specification of the components refer to the BOM

DESIGNED	WangLi/00291205	HL1ALONMM	03024BRV_SCHZH
REVIEWED	PengZhonghui/00210925	VER	PART_NUMBER
		B	03024BRV
			SHEET 3 OF 60
			HUAWEI TECH CO.,LTD.

4. SOC PWR2

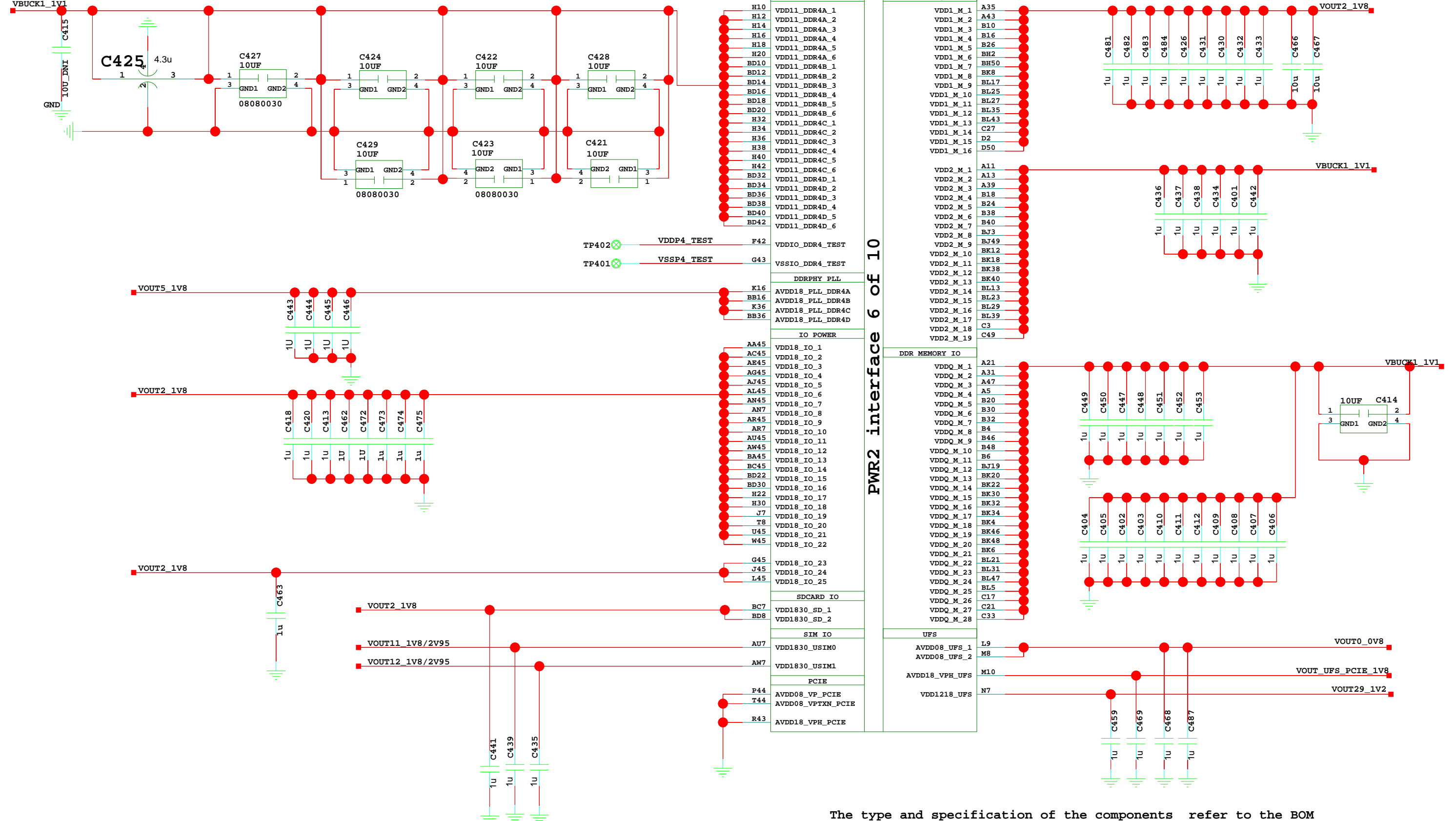

PWR2 interface 6 of 10

The type and specification of the components refer to the BOM

DESIGNED	WangLi/00291205	HL1ALONMM	03024BRV_SCHZH
REVIEWED	PengZhonghui/00210925	VER	PART_NUMBER
		B	03024BRV
			SHEET 4 OF 60
			HUAWEI TECH CO.,LTD.
			NA 2016-09-28
			ECA NO DATE

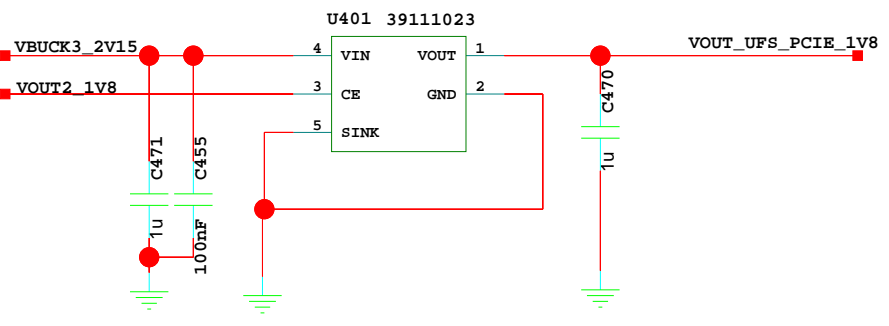

5. SOC PWR3

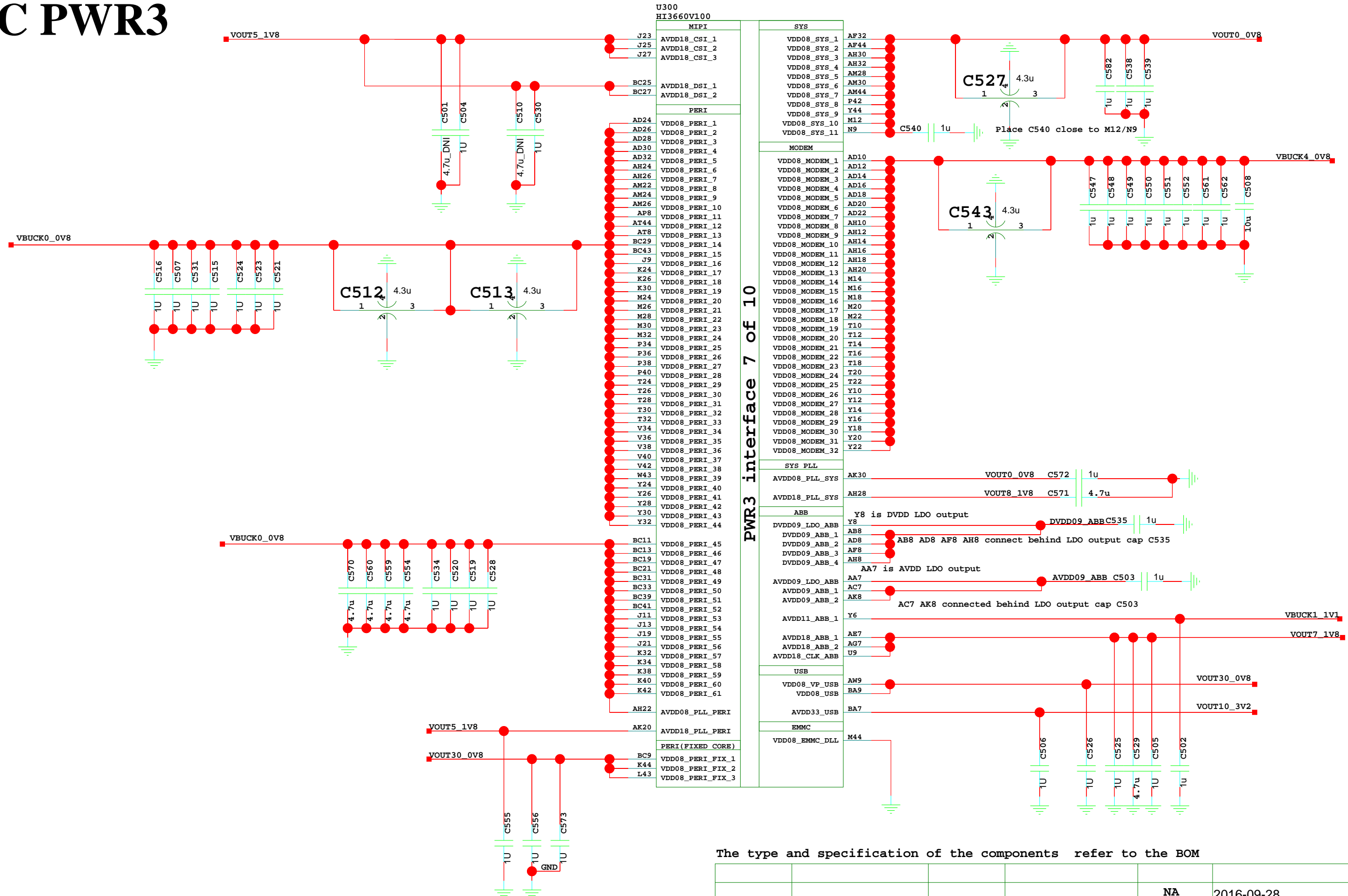

PWR3 interface 7 of 10

The type and specification of the components refer to the BOM

DESIGNED	WangLi/00291205	HL1ALONMM	03024BRV_SCHZH
REVIEWED	PengZhonghui/00210925	VER	SHEET 5 OF 60
		B	HUAWEI TECH CO.,LTD.
			NA 2016-09-28
			ECA NO DATE