

# Agera KBL-U SVT Schematic Block Diagram

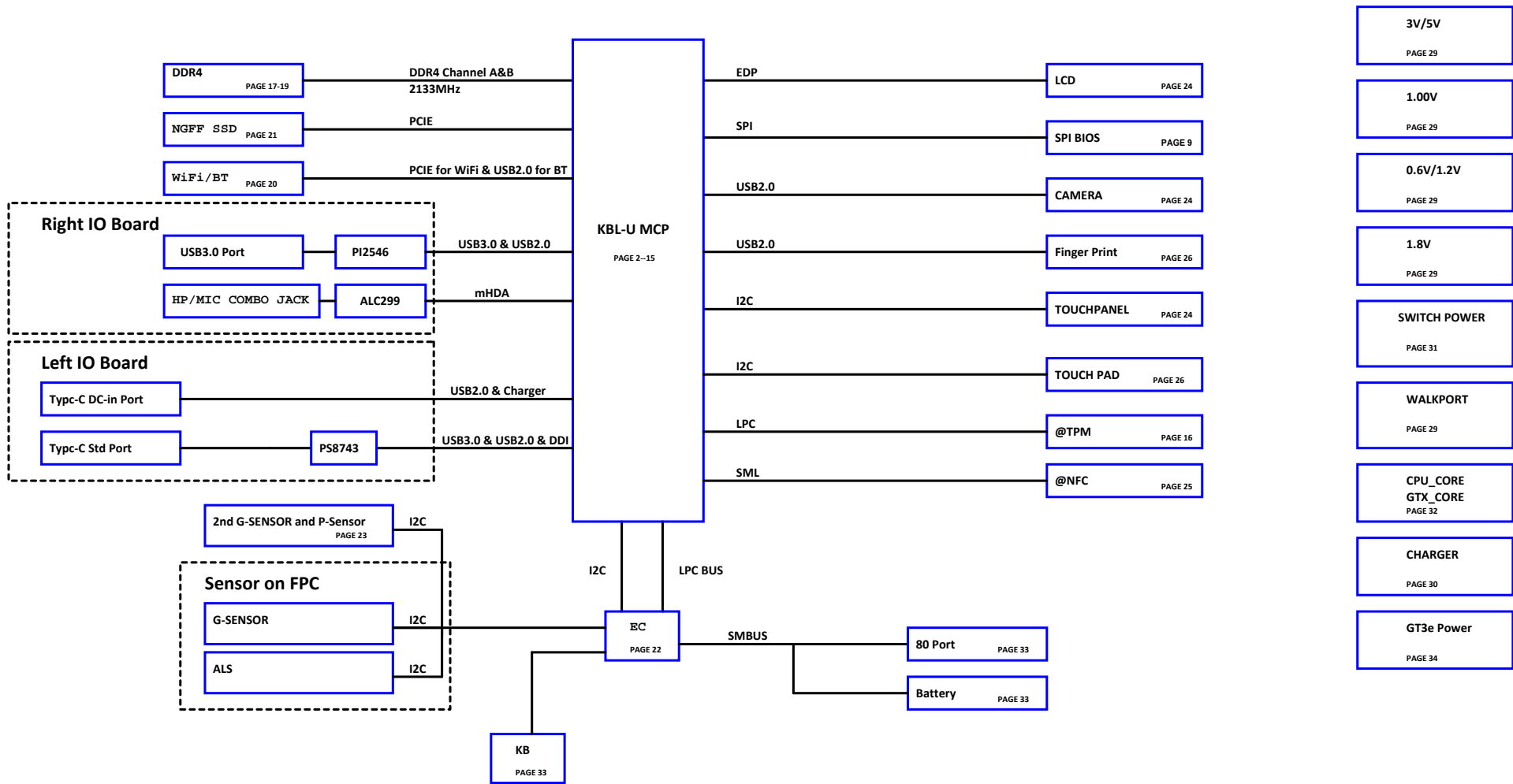

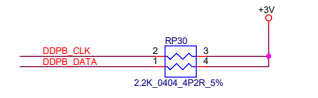

<b>lenovo</b> 联想		LENOVO.CRDN	
Title Kaby Lake MCP (DDI,EDP)			
Size C	Document Number YOGA910	Rev V1.0	
Date Thursday, June 30, 2016		Sheet 2 of 37	
PROPERTY NOTE: This document contains information confidential and property to LENOVO PND and shall not be reproduced or transferred to other documents or disclosed to others or used for any purpose other than that for which it was obtained without the expressed written consent of LENOVO PND.			

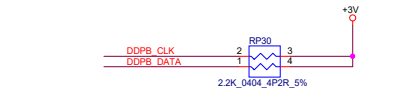
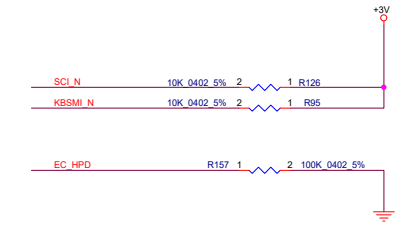
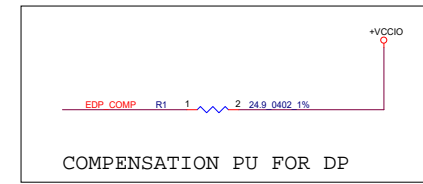
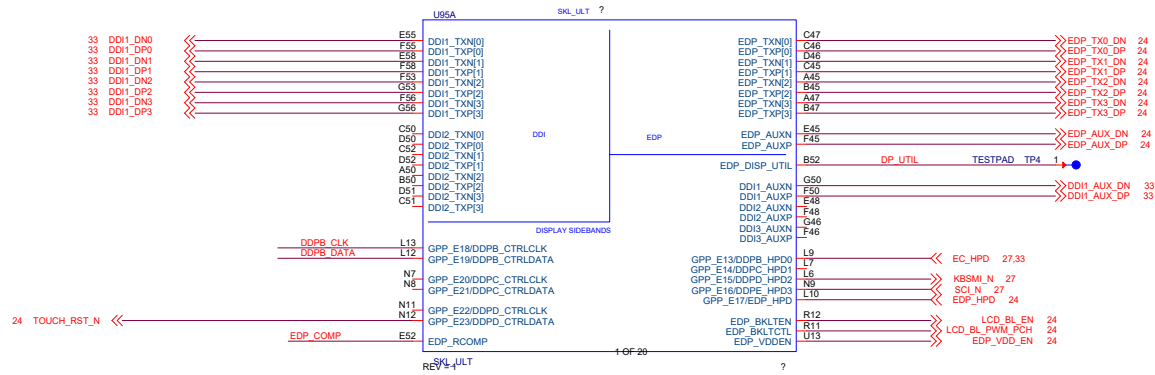
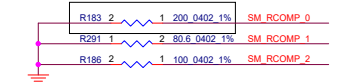
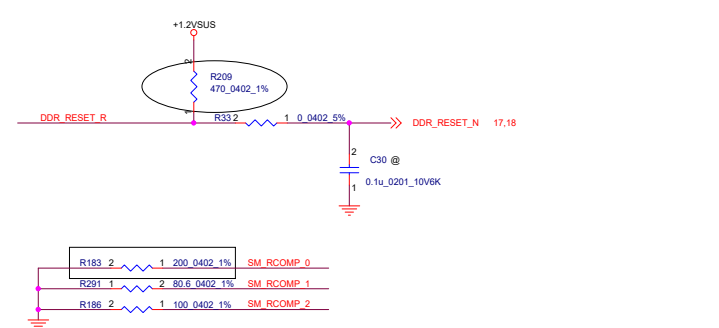
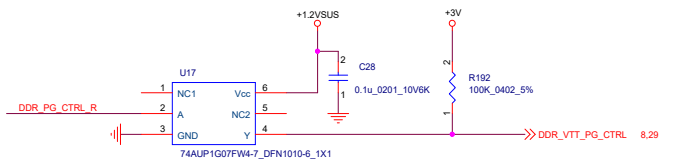
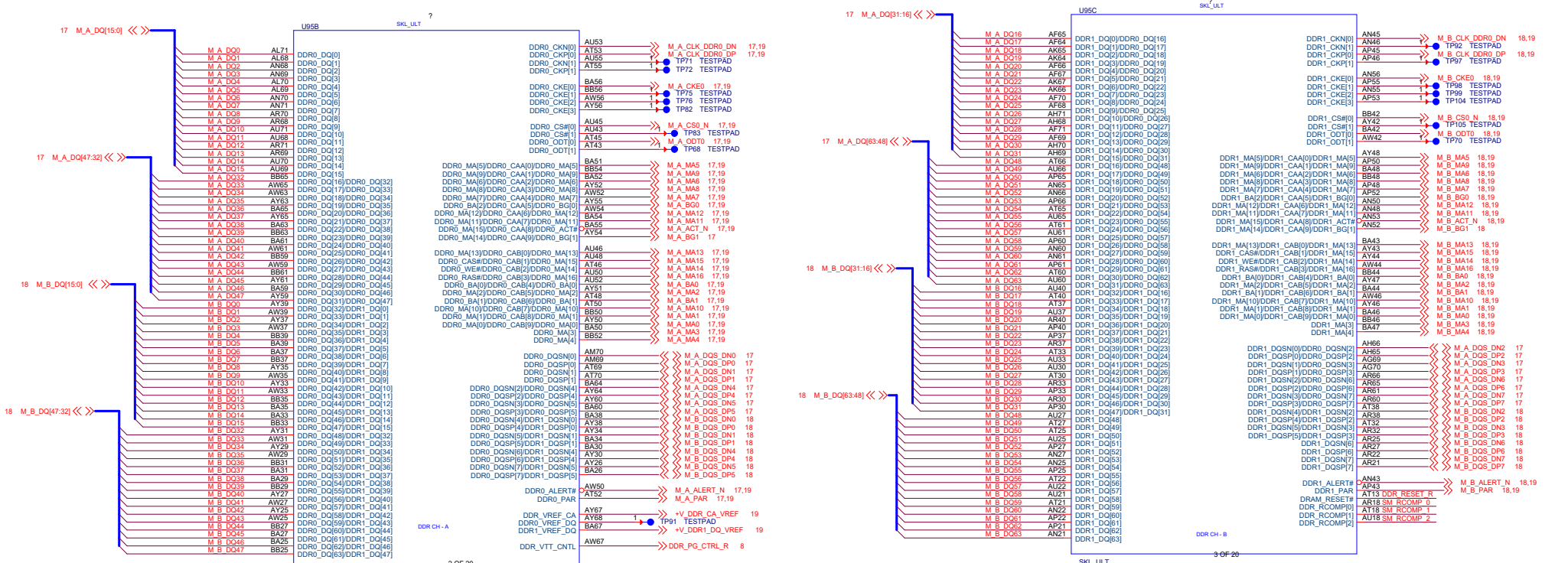

<b>lenovo</b> 联想		LENOVO.CRDN	
Title: Kaby Lake MCP ( PROCESSOR LPDDR3)			
Size	Document Number	Rev 1.0	
C	YOGA10		
Date: Thursday, June 30, 2016		Sheet 3 of 37	
PROPERTY NOTE: this document contains information confidential and property to LENOVO PND and shall not be reproduced or transferred to other documents or disclosed to others or used for any purpose other than that for which it was obtained without the expressed written consent of LENOVO PND.			

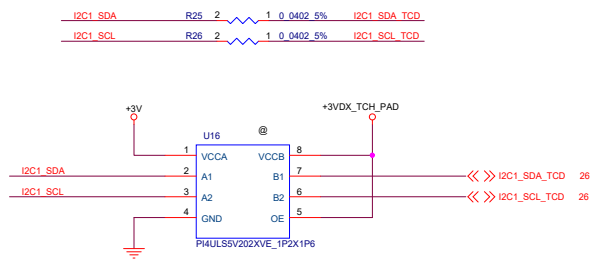
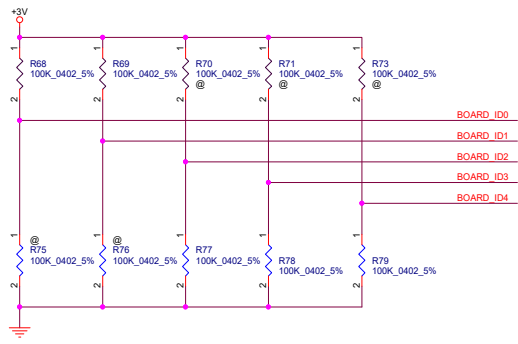
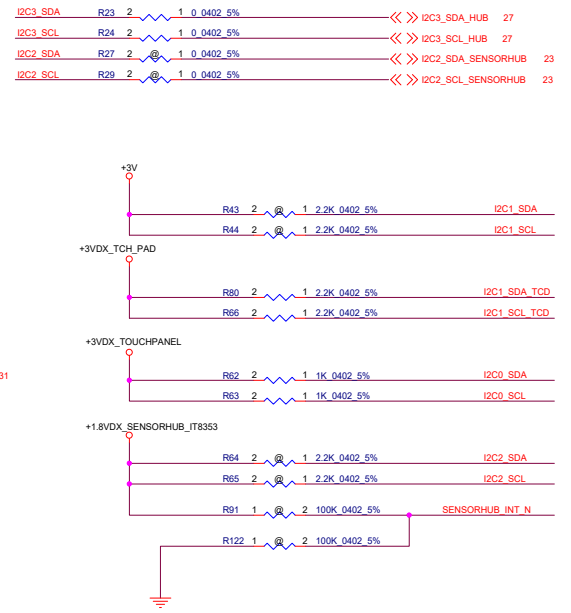
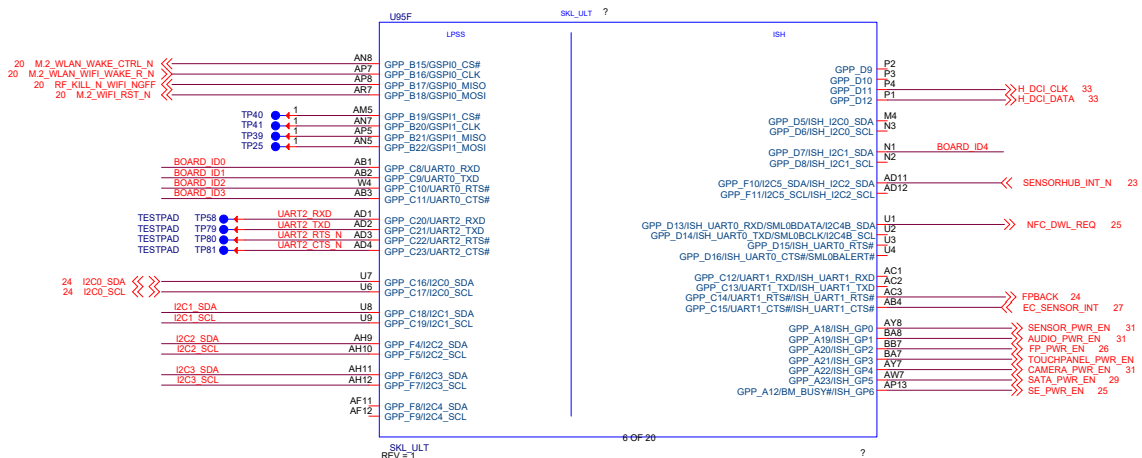

R163, R163	R580, R581, R146, R154	R183	R571, R572, R574, R575, R576, R577, R578, R579	BOARD_ID4	BOARD_ID3	BOARD_ID2	BOARD_ID1	BOARD_ID0	Description
Stuff	Dummy #	200ohm	0ohm	0	0	0	0	0	Samsung 8Gb x16 DDR4 2133
Stuff	Dummy #	200ohm	0ohm	0	0	0	0	1	Samsung 4Gb x16 DDR4 2133
Dummy #	Stuff	121ohm	240ohm	0	0	0	1	0	Micron 16Gb x16 DDR4 2133
Stuff	Dummy #	200ohm	0ohm	0	0	0	0	1	Micron 8Gb x16 DDR4 2133
Stuff	Dummy #	200ohm	0ohm	0	0	1	0	0	Samsung 8Gb x16 DDR4 2400
Stuff	Dummy #	200ohm	0ohm	0	0	1	0	1	Samsung 4Gb x16 DDR4 2400
Dummy #	Stuff	121ohm	240ohm	0	0	1	1	0	Micron 16Gb x16 DDR4 2400
Stuff	Dummy #	200ohm	0ohm	0	0	1	1	1	Micron 8Gb x16 DDR4 2400
Dummy #	Stuff	121ohm	240ohm	0	1	0	0	0	Samsung 16Gb x16 DDR4 2400

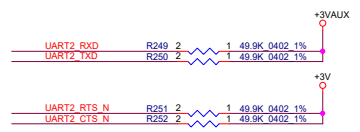

**lenovo** 联想

LENOVO.CRDN

Title: Kaby Lake MCP (PCIe USB GPIO)

Size C Document Number YOGA10 Rev v1.0

Date: Thursday, June 30, 2016 Sheet 4 of 37

PROPERTY NOTE: this document contains information confidential and property to LENOVO PND and shall not be reproduced or transferred to other documents or disclosed to others or used for any purpose other than that for which it was obtained without the expressed written consent of LENOVO PND.

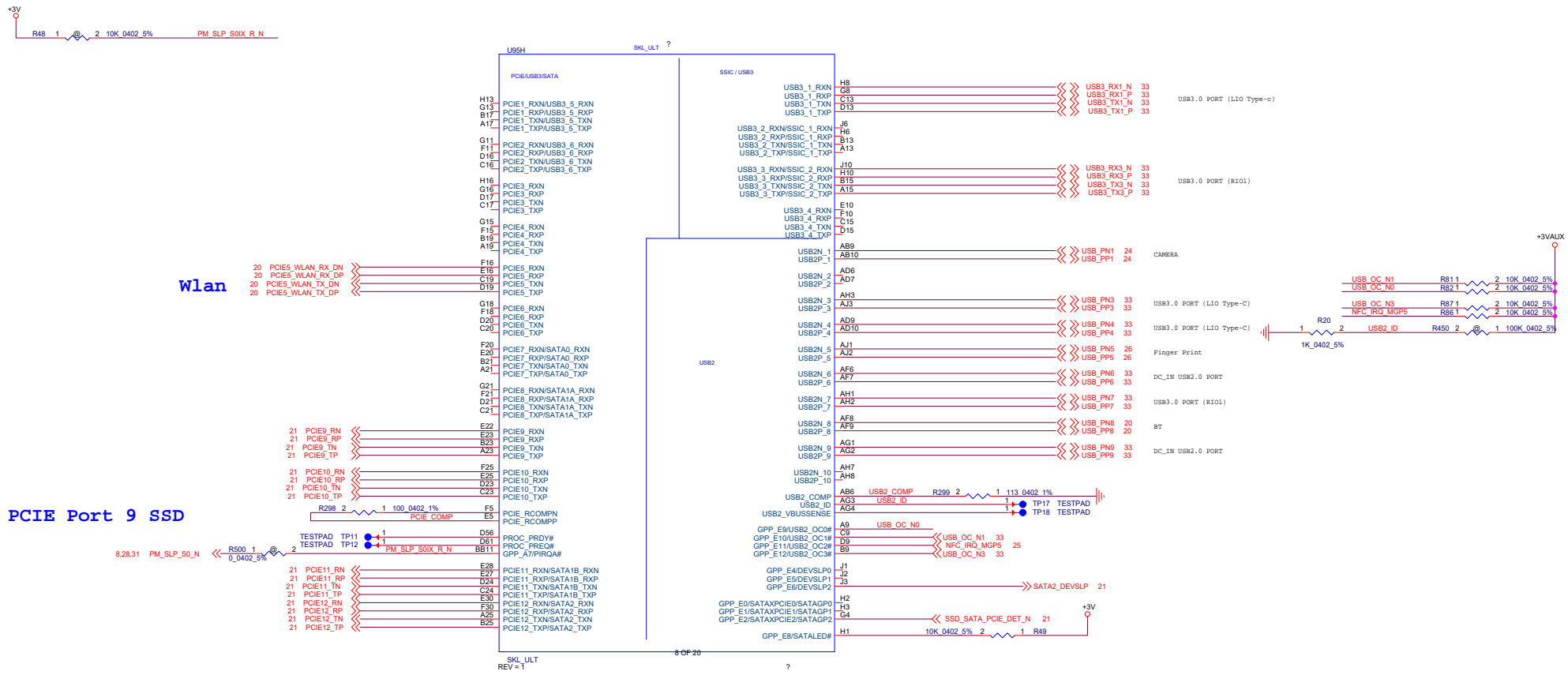

**PCIE Port 9 SSD**

**Wlan**

<b>lenovo 联想</b>		LENOVO.CRDN
Title: Kaby Lake MCP (PCIE USB GPIO)		
Size: C	Document Number: YOGA10	Rev: v1.0
Date: Thursday, June 30, 2016	Sheet: 5	of: 37
<small>PROPERTY NOTE: this document contains information confidential and property to LENOVO PND and shall not be reproduced or transferred to other documents or disclosed to others or used for any purpose other than that for which it was obtained without the expressed written consent of LENOVO PND.</small>		