

# Baseband Schematic

- 1. Contents
- 2. RES
- 3. SOC PWR1
- 4. SOC PWR2
- 5. SOC PWR3
- 6. SOC HS Interface
- 7. SOC GPIO Interface
- 8. SOC RF Interface
- 9. SOC GND & NC
- 10. PMU LDO
- 11. PMU BUCK
- 12. PMU MISC & BUCKBOOST
- 13. HI6422
- 14. UFS and LPDDR4
- 15. Battery & Fuel gauge
- 16. Charge Management
- 17. LCD Interface
- 18. Flash /Front CAM
- 19. Main CAM
  
- 20. USB
- 21. Main FPC
- 22. Codec HI6403
- 23. Direct Charger
- 24. SMART PA
- 25. Audio
- 26. Headphone
- 27. X-Sensor
- 28. SIM Card/SD
- 29. LED /KEY/IR
- 30. Test Point/Shielding

# MODEM Schematic

- 31. RF Interface
- 32. APT Power
- 33. RF Transceiver\_0
- 34. RF FRONT END HB
- 35. RF FRONT END B42
- 36. RF FRONT END MB
- 37. RF Front End LB
- 38. RF Front End Switch /Main ANT
- 39. RF Front End Diversity
- 40. RF Front End Diversity
- 41. Reserved for CDMA Modem
- 42. Reserved for CDMA Modem
- 43. Reserved for CDMA Modem
- 44. Reserved for CDMA Modem
- 45. Reserved for CDMA Modem
- 46. Reserved for CDMA Modem
- 47. Reserved for CDMA Modem
- 48. Reserved for CDMA Modem
- 49. Reserved
- 50. Reserved
- 51. BCM43455 BB
- 52. BCM43455 POWER
- 53. Reserved
- 54. WALN RF0
- 55. WLAN RF1
- 56. GPS
- 57. NFC
- 58. RF Transceiver2
- 59. Reserved
- 60. ANT Tuner

The type and specification of the components refer to the BOM

				NA	20180829
				ECA NO	DATE
DESIGNED	HUAWEI	MAGICAL2		Magical2	
REVIEWED	HUAWEI				
		VER	PART_NUMBER	SHEET 1 OF 75	
		D	Magical2	HUAWEI TECH CO.,LTD.	

# 2.RES

A

A

B

B

C

C

D

D

The type and specification of the components refer to the BOM

					Magical2
				NA	20180829
				ECA NO	DATE
DESIGNED	HUAWEI	MAGICAL2		Magical2	
REVIEWED	HUAWEI				
		VER	PART_NUMBER	SHEET 2 OF 75	
		D	Magical2	HUAWEI TECH CO.,LTD.	

# 3. SOC PWR1

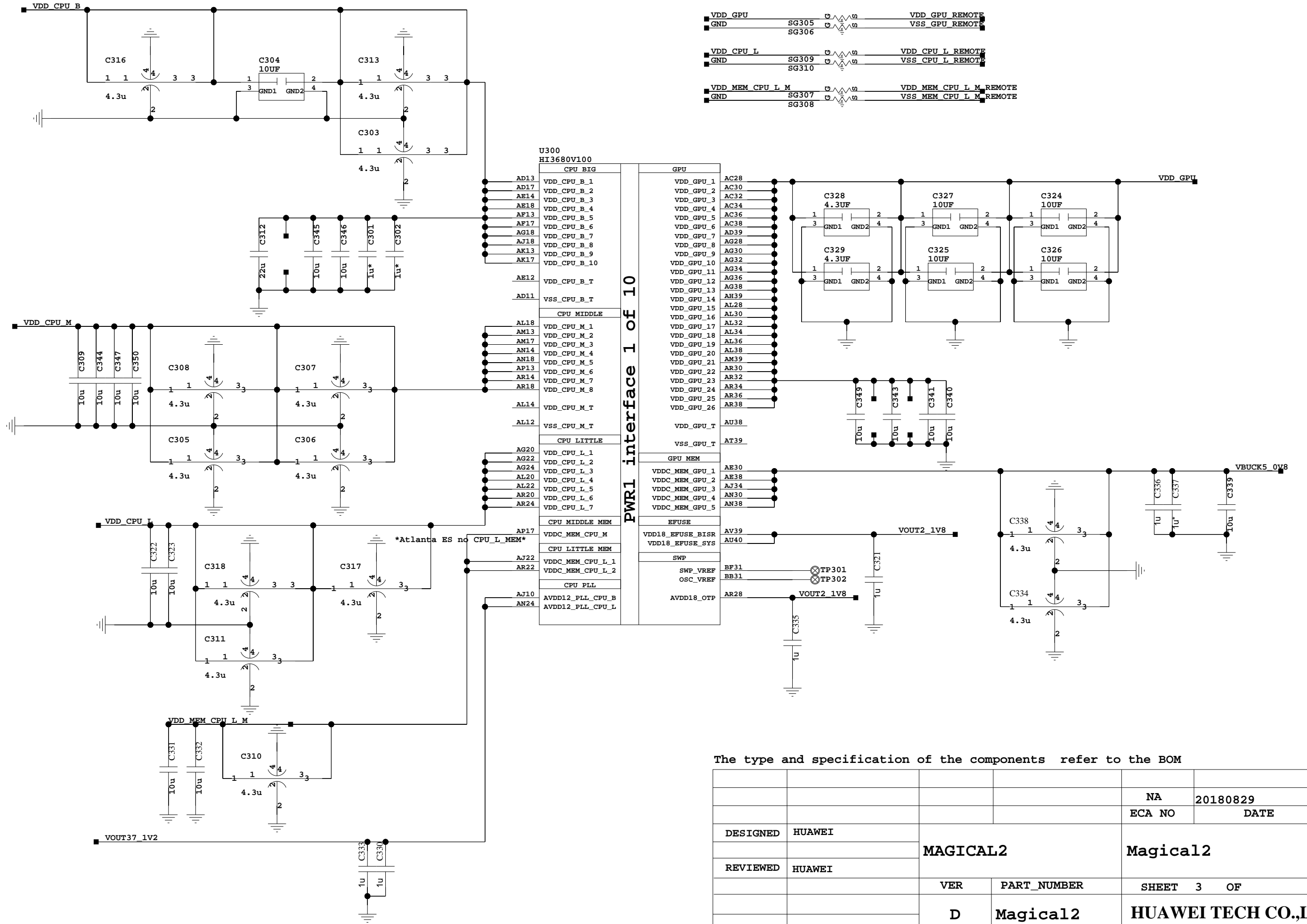

The type and specification of the components refer to the BOM

				NA	20180829
				ECA NO	DATE
DESIGNED	HUAWEI	MAGICAL2		Magical2	
REVIEWED	HUAWEI				
		VER	PART_NUMBER	SHEET 3 OF	
		D	Magical2	HUAWEI TECH CO.,LTD.	

# 4. SOC PWR2

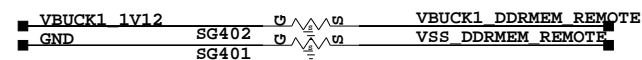

U300  
 HI3680V100

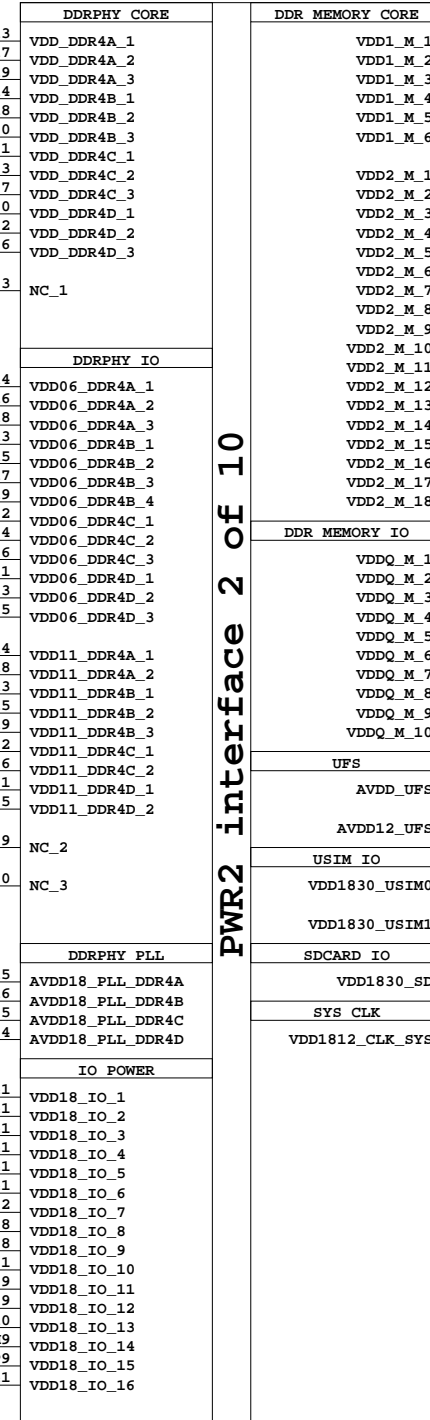

PWR2 interface 2 of 10

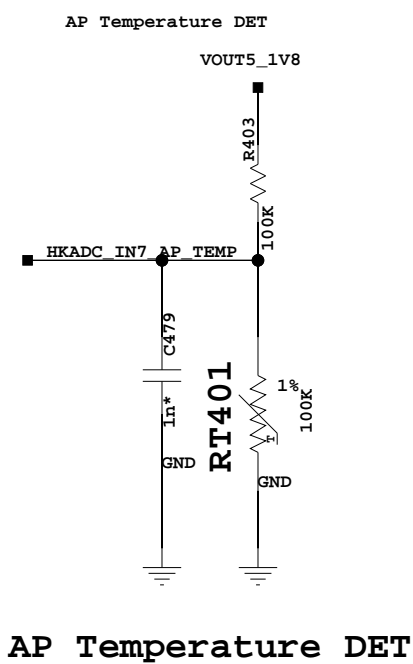
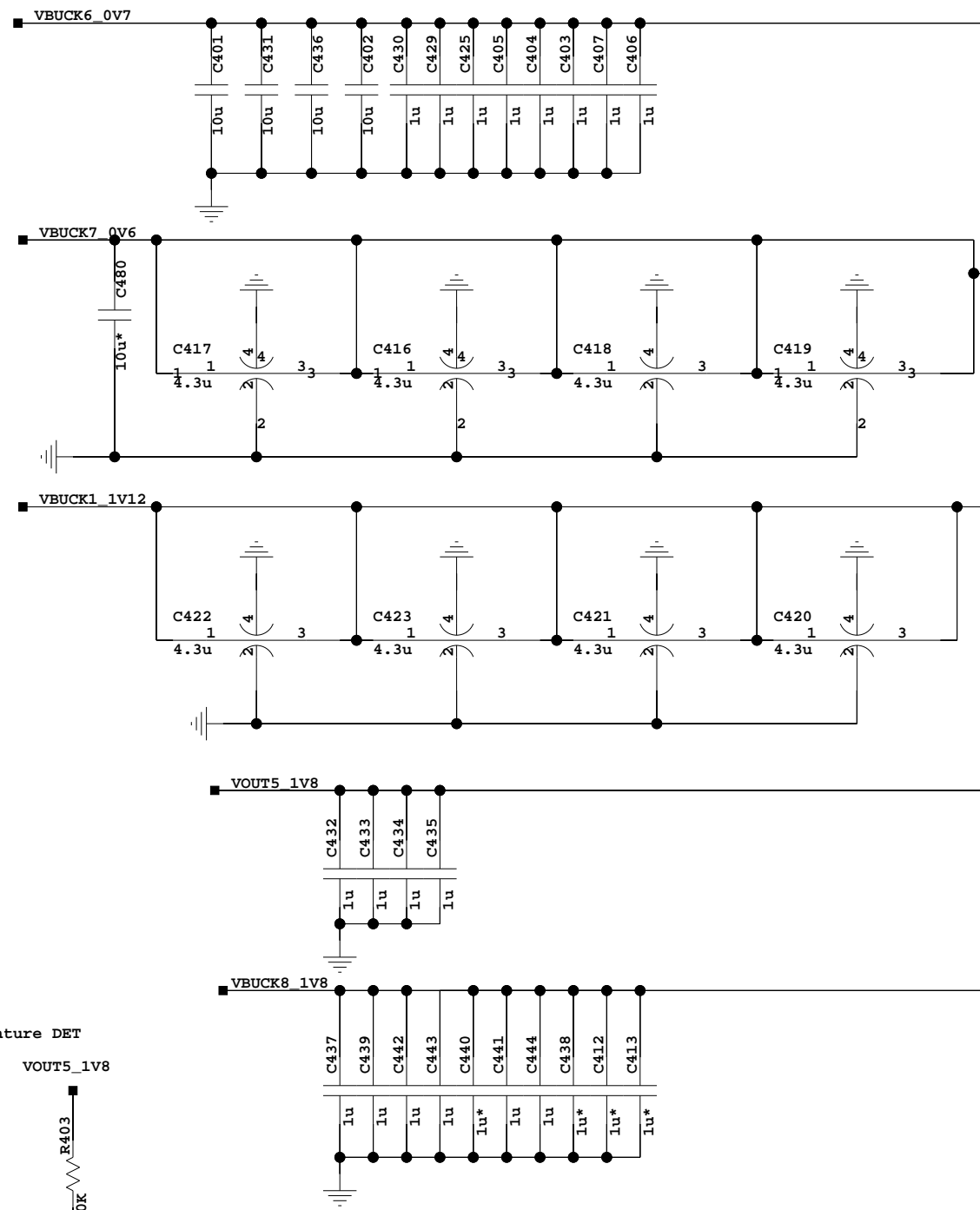

The type and specification of the components refer to the BOM

				NA	20180829
				ECA NO	DATE
DESIGNED	HUAWEI	MAGICAL2		Magical2	
REVIEWED	HUAWEI	VER	PART_NUMBER	SHEET 4 OF 75	
		D	Magical2	HUAWEI TECH CO.,LTD.	

# 5. SOC PWR3

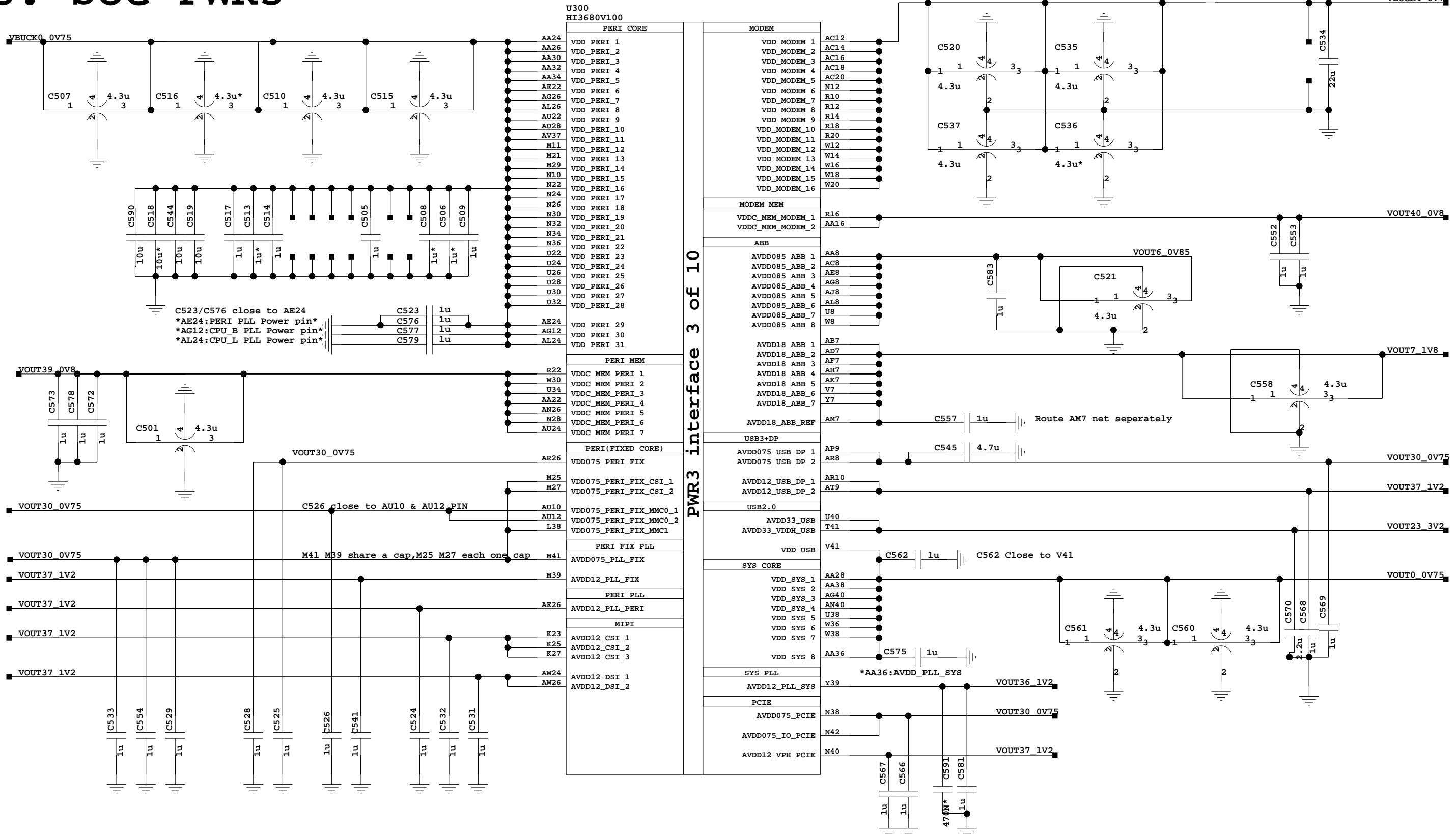
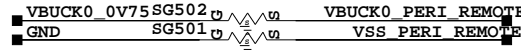

The type and specification of the components refer to the BOM

				NA	20180829
				ECA NO	DATE
DESIGNED	HUAWEI	MAGICAL2		Magical2	
REVIEWED	HUAWEI	VER	PART_NUMBER	SHEET 5 OF 75	
		D	Magical2	HUAWEI TECH CO.,LTD.	