

Baseband Schematic

1. Contents
2. Block Diagramm
3. SOC PWR1
4. SOC PWR2
5. SOC PWR3
6. SOC HS Interface
7. SOC GPIO Interface
8. SOC RF Interface
9. SOC GND & NC
10. PMU LDO
11. PMU BUCK
12. PMU MISC & BUCKBOOST
13. HI6422-2
14. UFS and LPDDR4
15. Battery & Fuel gauge
16. Charge Management
17. LCD Interface
18. Direct Charge LoadSwitch
19. Flash LED
20. Camera Interface
21. TYPEC INTERFACE
22. Codec HI6403
23. MIC/VIB
24. Headphone
25. Audio
26. X-Sensor1
27. X-Sensor2
28. SIM Card
29. FPC Interface
30. Test Point/Shielding

MODEM Schematic

31. RF Interface
32. APT Power
33. RF Transceiver_0
34. RF FRONT END HB
35. RF FRONT END B42
36. RF FRONT END MB
37. RF Front End LB
38. RF Front End Switch /Main ANT
39. RF Front End Diversity
40. RF Front End Diversity
41. Reserved for CDMA Modem
42. Reserved for CDMA Modem
43. Reserved for CDMA Modem
44. Reserved for CDMA Modem
45. Reserved for CDMA Modem
46. Reserved for CDMA Modem
47. Reserved for CDMA Modem
48. Reserved for CDMA Modem
49. Reserved
50. Reserved
51. BCM43455 BB
52. BCM43455 POWER
53. Reserved
54. WALN RF0
55. WLAN RF1
56. GPS
57. NFC
58. RF Transceiver2
59. Reserved
60. ANT Tuner

The type and specification of the components refer to the BOM

| | | | | | |
|----------|----------------------------------|-----|-------------|----------------------|------------|
| | | | | | |
| | | | | | 2017-11-15 |
| | | | | ECA NO | DATE |
| DESIGNED | Daiqifeng 360448/Gedeyong 294321 | | | HL2EMILYM1 | |
| REVIEWED | Zhuli 371266 | | | 03024RBX_SCHZH | |
| | | VER | PART_NUMBER | SHEET 1 OF 60 | |
| | | D | 03024RBX | HUAWEI TECH CO.,LTD. | |

2. Block Diagramm

The type and specification of the components refer to the BOM

| | | | | | |
|----------|----------------------------------|------------|-------------|----------------------|------------|
| | | | | | |
| | | | | | 2017-11-15 |
| | | | | ECA NO | DATE |
| DESIGNED | Daiqifeng 360448/Gedeyong 294321 | | | 03024RBX_SCHZH | |
| | | HL2EMILYM1 | | | |
| REVIEWED | Zhuli 371266 | | | | |
| | | VER | PART_NUMBER | SHEET 2 OF 60 | |
| | | D | 03024RBX | HUAWEI TECH CO.,LTD. | |

3.SOC PWR1

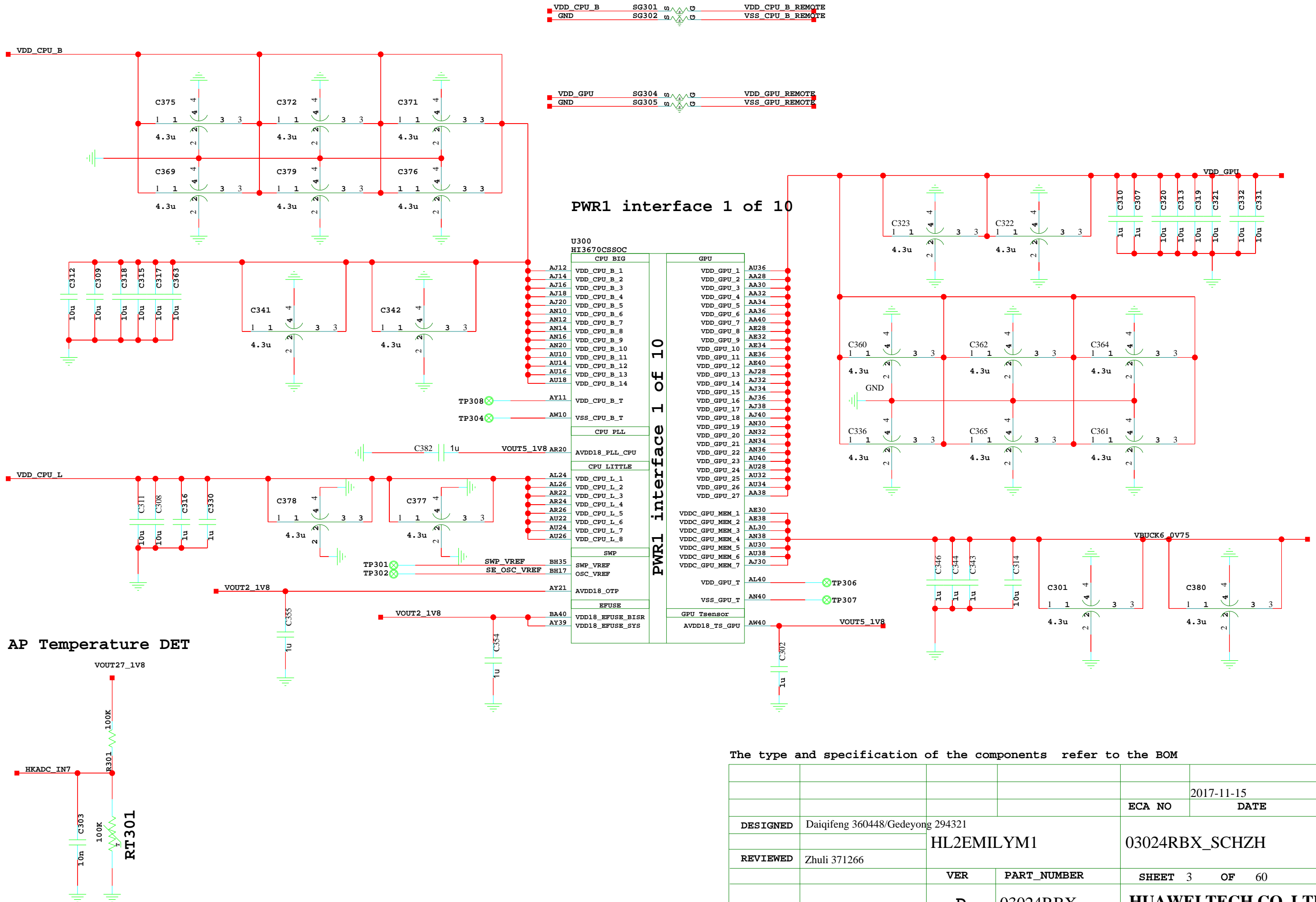

The type and specification of the components refer to the BOM

| | | | |
|----------|----------------------------------|----------------------|----------------|
| DESIGNED | Daiqifeng 360448/Gedeyong 294321 | HL2EMILYM1 | 03024RBX_SCHZH |
| REVIEWED | Zhuli 371266 | | |
| | | VER | PART_NUMBER |
| | | D | 03024RBX |
| | | SHEET | 3 OF 60 |
| | | HUAWEI TECH CO.,LTD. | |

ECA NO: 2017-11-15
DATE

4.SOC PWR2

PWR2 interface 2 of 10

Ensure VBUCK1_1V1_FB_R and VBUCK7_0V6_FB_R near the CAP

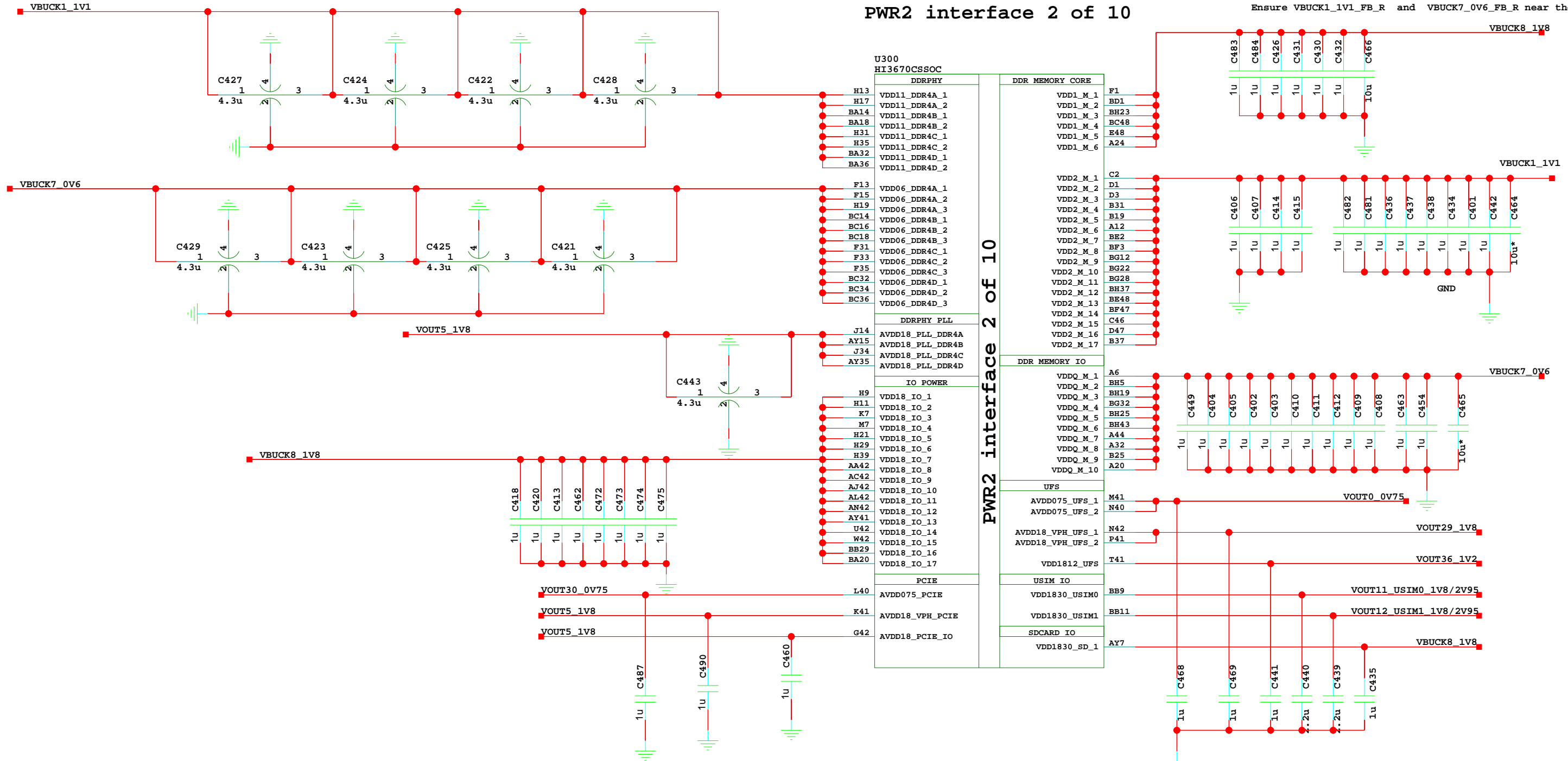

The type and specification of the components refer to the BOM

| | | | | | |
|----------|----------------------------------|-----|-------------|----------------------|------------|
| | | | | | |
| | | | | | 2017-11-15 |
| | | | | ECA NO | DATE |
| DESIGNED | Daiqifeng 360448/Gedeyong 294321 | | HL2EMILYM1 | 03024RBX_SCHZH | |
| REVIEWED | Zhuli 371266 | | | | |
| | | VER | PART_NUMBER | SHEET | 4 OF 60 |
| | | D | 03024RBX | HUAWAI TECH CO.,LTD. | |

5.SOC PWR3

PWR3 interface 3 of 10

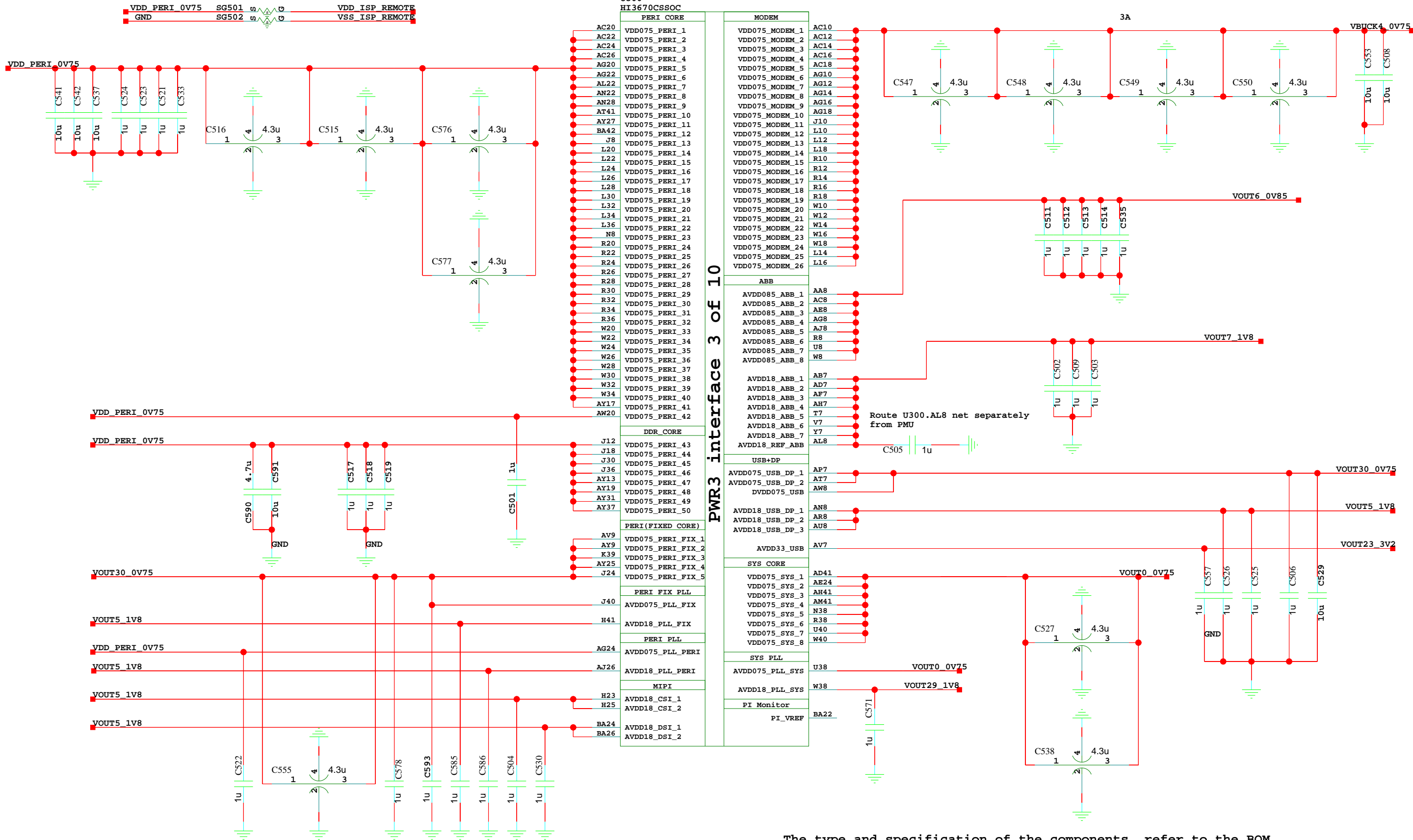

PWR3 interface 3 of 10

The type and specification of the components refer to the BOM

| | | | | | |
|----------|----------------------------------|-------------|----------------------|--------|----------------|
| | | | | | 2017-11-15 |
| | | | | ECA NO | DATE |
| DESIGNED | Daiqifeng 360448/Gedeyong 294321 | | HL2EMILYM1 | | 03024RBX_SCHZH |
| REVIEWED | Zhuli 371266 | | | | |
| | VER | PART_NUMBER | SHEET 5 OF 60 | | |
| | D | 03024RBX | HUAWEI TECH CO.,LTD. | | |