

For SDM636/SDM660, OPTION1 is Hi-Z

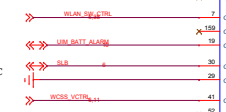

uUSB_TYPEC is Hi-Z for Type-C
uUSB_TYPEC is LOW for uUSB

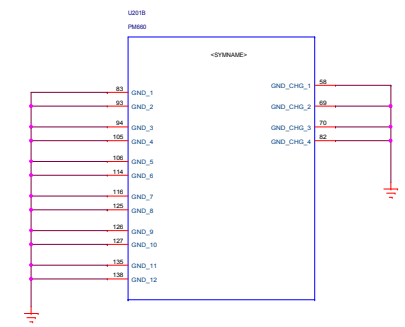

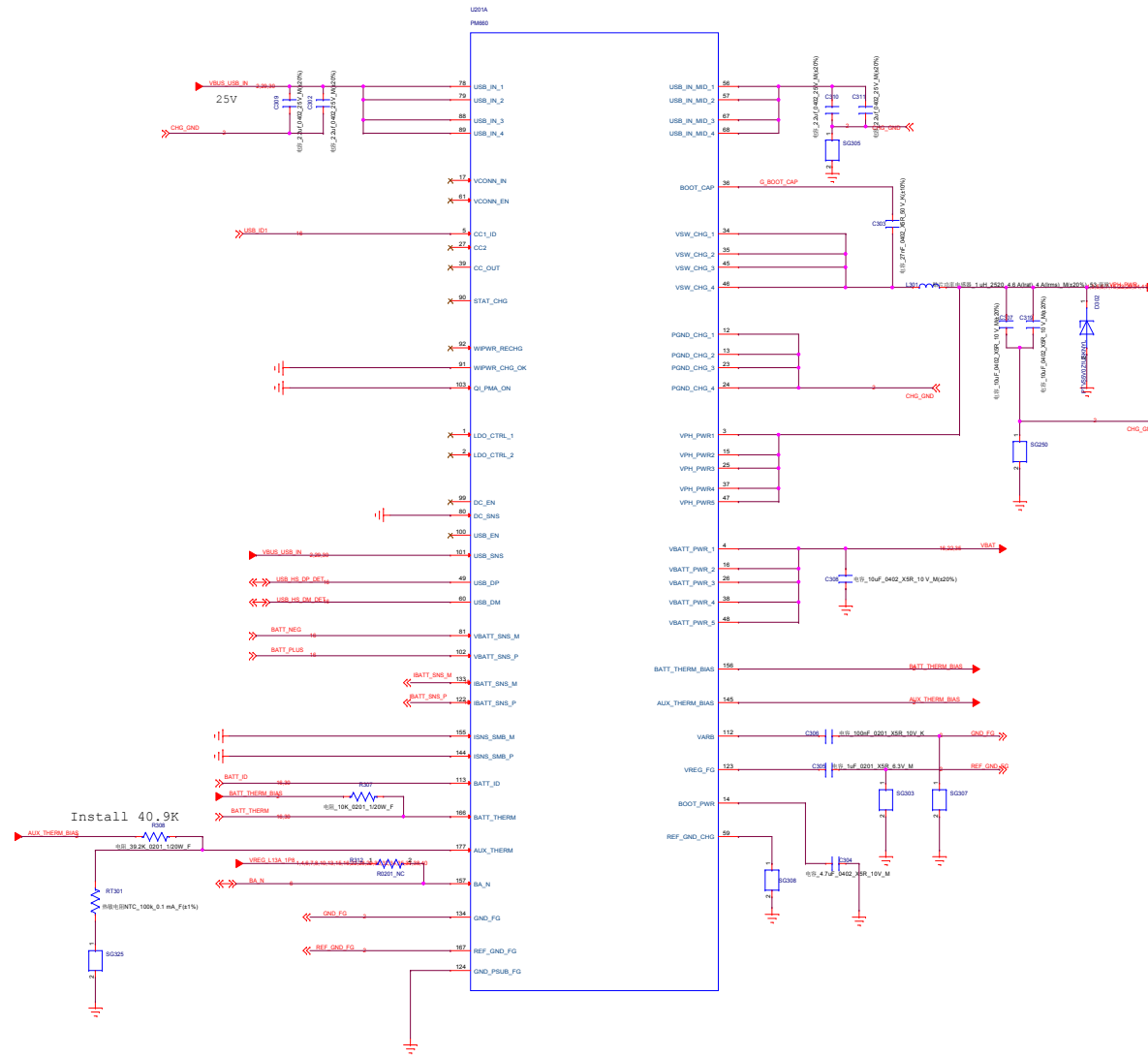

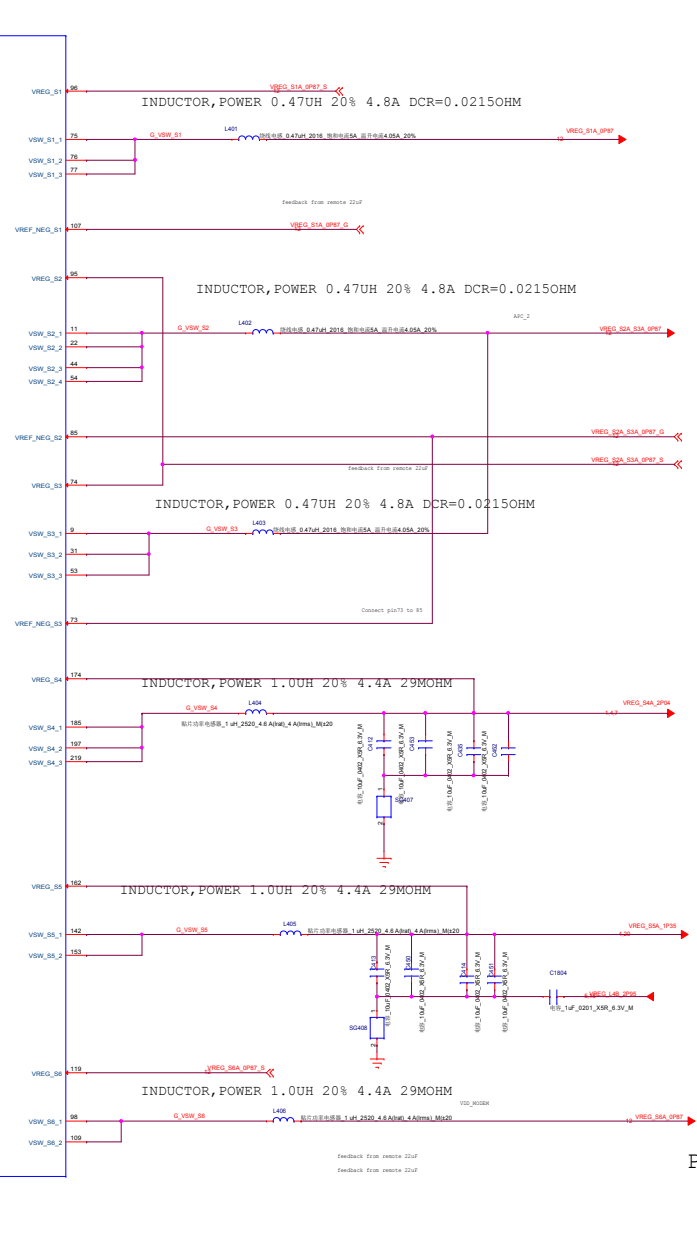
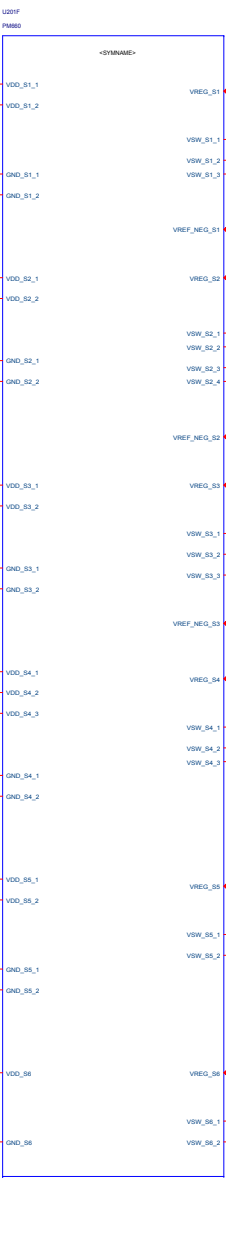
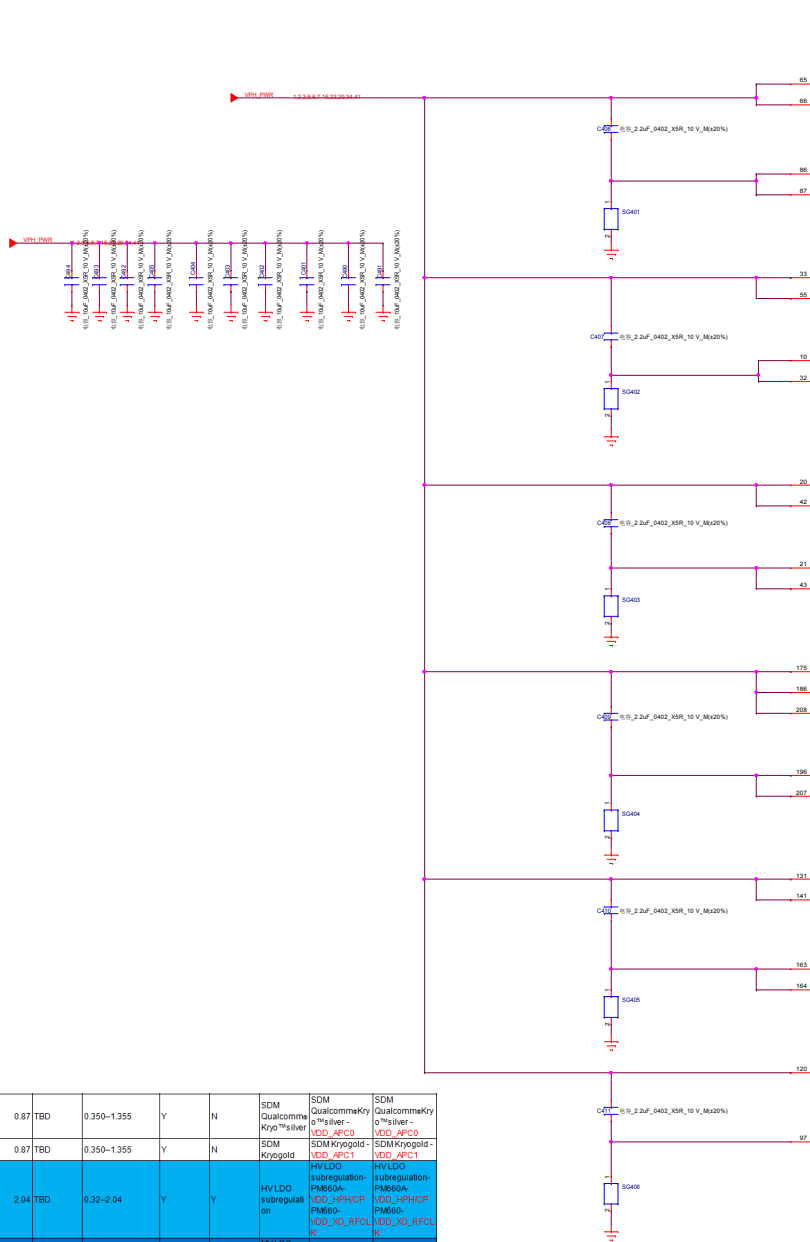

S1A	FTS426 SMPS	4000	0.87	TBD	0.350-1.355	Y	N	SDM Qualcomm Kyro™ Silver	SDM Qualcomm Kyro™ Silver	SDM Qualcomm Kyro™ Silver
S2A-SA	FTS426 SMPS	8000	0.87	TBD	0.350-1.355	Y	N	SDM KryoGold	SDM KryoGold	SDM KryoGold
S4A	HFS3 SMPS	3000	2.04	TBD	0.32-2.04	Y	Y	HV LDO subregulation	HV LDO subregulation	HV LDO subregulation
S5A	HFS3 SMPS	3000	1.35	TBD	0.32-2.04	Y	Y	MV LDO subregulation	MV LDO subregulation	MV LDO subregulation
S6A	HFS3 SMPS	2000	0.87	TBD	0.32-2.04	N	N	SDM modern	SDM modern	SDM modern

PM660 BUCK CONVERTER

